

SPECIFICATIONS

Model No.		PLFE-9B-4
Dimensions	Length	150mm
	Width	65mm
	Height	105mm
Weight		800g

CHARACTERISTICS

Nominal Voltage		12V
Capacity		3Ah
Nominal Power		36Wh
Initial Impedance		<12mΩ
Working Voltage		8V~14.4V
Operating Temperature	Charge	0°C ~ +45°C
	Discharge	-20°C ~ +55°C
Storage Temperature		0°C~30°C
		1.5A (0.5C), Max. 6A (2C)
Charge Retention		30 days ≥95%
Discharge	Continuous	120A (40C)
	Maximum	210A (70C, 15S)
CCA (-18°C storage for 20h)		90A (30C, 15S)
Cycle Life		2000 cycles



PLFE-9B-4

REPLACEMENTS

YT9B-4

DRAWINGS

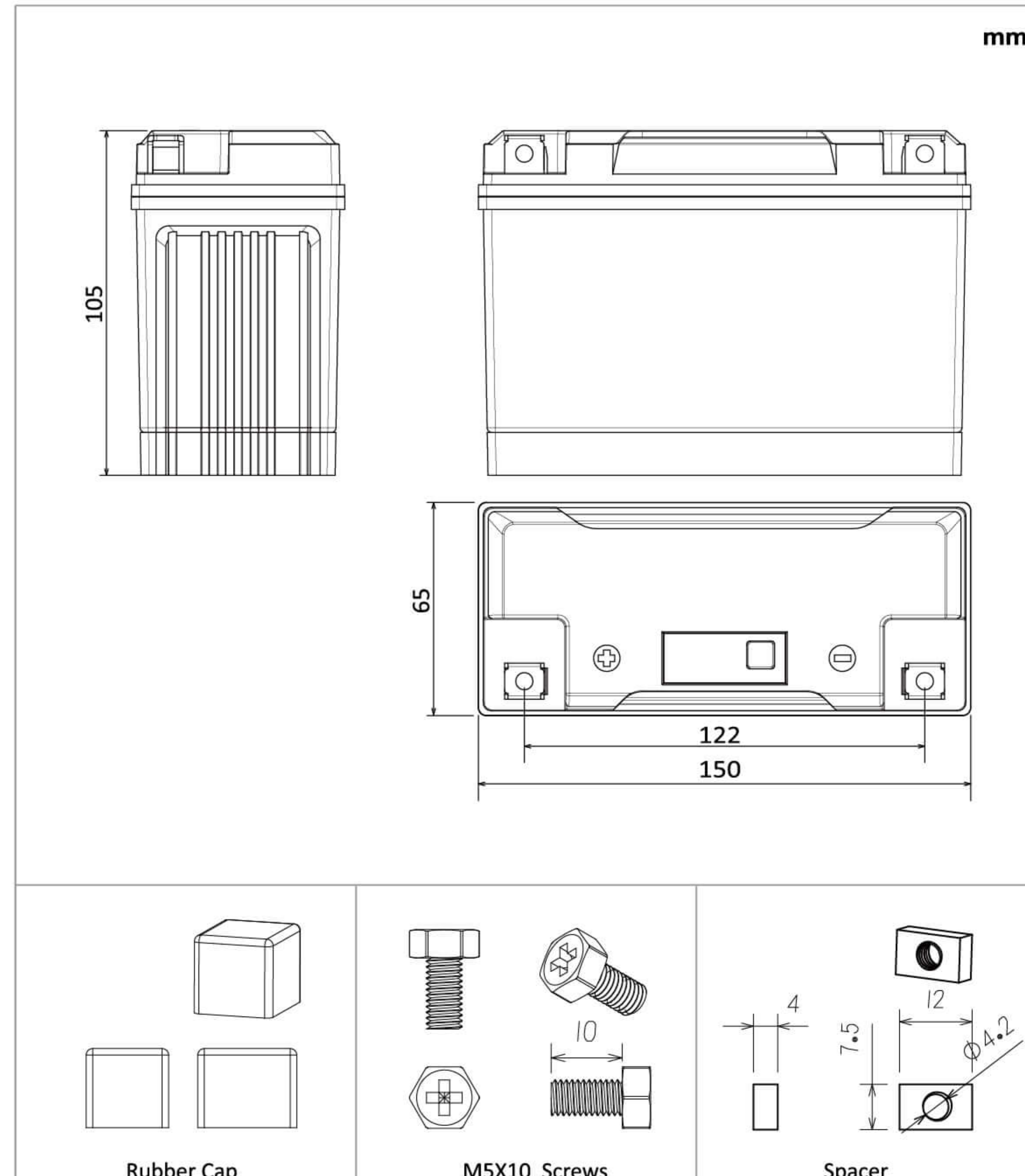

DISCHARGING GRAPH

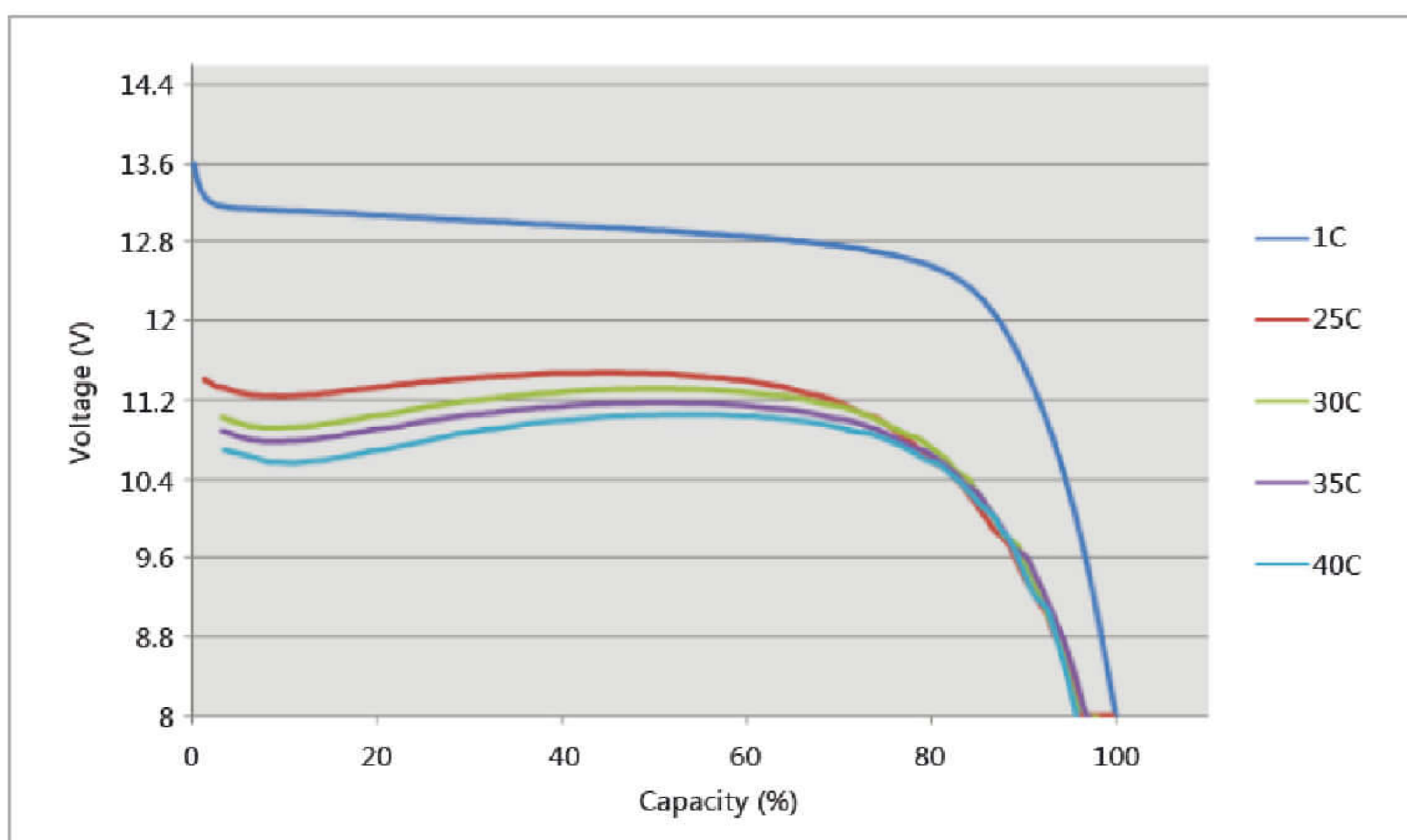

CERTIFICATIONS

UN38.3 CE