

## 2V TUBULAR GEL SERIES VRLA BATTERY

The OPzV series adopts an Immobilized Gel and Tubular Positive Plate technology. It offers high reliability and stable performance. By using die-casted positive grid and patented active material formula, it exceeds the DIN standard values and offer 20+ years design life in float service. It is very suitable for cyclic use under extreme operating conditions. This series is recommended for telecom outdoor applications, renewable energy systems and other harsh environment applications.

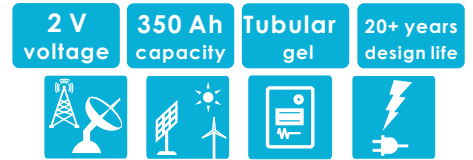

### SPECIFICATIONS

Nominal Voltage (V)	2
Designed Floating Life (20°C)	20+ Years
Nominal Capacity (20°C)	350 Ah @ C <sub>10</sub> (to 1.80Vpc)
Dimensions	L124mm×W206mm×H506mm
Approx. Weight	28.5 kg (62.8 lbs)
Terminal Type	Female Copper Insert M8 (torque:10~12N.m)
Internal Resistance	Approx. 0.70mOhm (fully charged @ 20°C)
Max. Charge Current	70 A
Max. Discharge Current (5S)	1500 A
Short Circuit Current	2850 A
Self Discharge	Approx. 2% per month @ 20°C
Ambient Temperature	Discharge: -40~65°C Charge: -30~65°C Storage: -25~45°C
Float Charge Voltage (20~25°C)	2.25-2.29V (-3mV / °C/ cell)
Equalize Charge Voltage (20~25°C)	2.35-2.40V (-5mV / °C/ cell)
Container Material	ABS(UL94-V0 optional)



### Complied standards

- IEC 60896-21/22
- DIN40742
- IEC61427
- YD/T1360
- Eurobat guide, long life
- BS6290 part 4
- UL1989

### DIMENSIONS

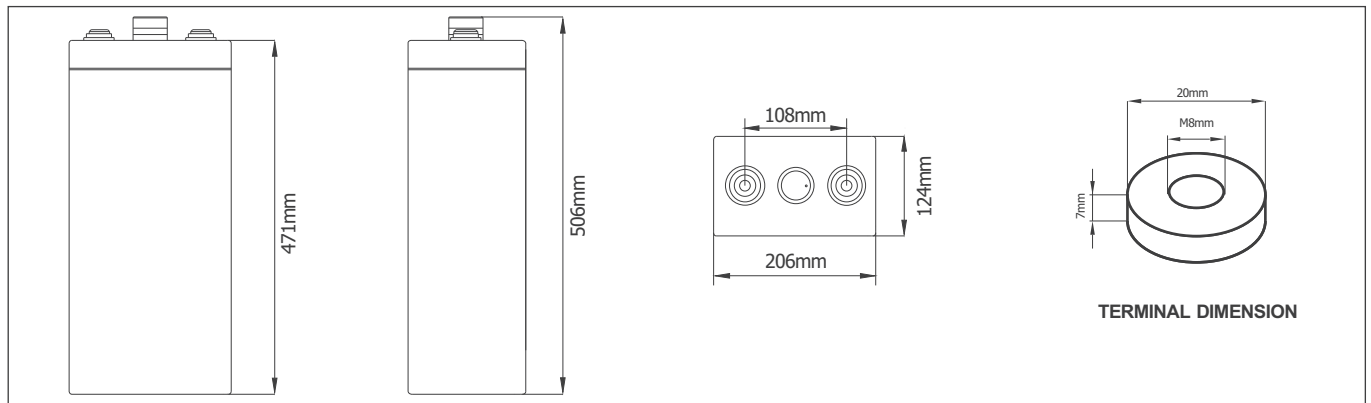

### BATTERY DISCHARGE TABLE

#### Constant Current Discharge Characteristics: Amps (20°C)

F.V/Tim e	10m in	15m in	30m in	1h	2h	3h	5h	8h	10h
1.90V	128	125	117	98.0	83.4	70.0	51.8	37.1	30.6
1.87V	175	163	145	114	93.3	77.1	56.2	39.4	32.4
1.85V	201	184	159	125	103	83.0	59.9	41.2	33.7
1.83V	234	205	172	138	110	87.6	61.3	42.5	34.3
1.80V	262	238	192	152	116	92.0	62.5	43.1	35.0
1.75V	278	261	225	165	121	94.5	63.7	43.8	36.1
1.70V	303	287	247	174	126	96.3	64.8	44.5	36.8
1.65V	353	323	270	186	129	98.0	66.2	45.2	37.5
1.60V	385	355	286	191	132	100	67.6	46.0	38.2

#### Constant Power Discharge Characteristics: W/cell (20°C)

F.V/Tim e	10m in	15m in	30m in	1h	2h	3h	5h	8h	10h
1.90V	248	242	227	192	165	139	104	74.6	61.9
1.87V	331	311	277	221	182	152	112	78.7	64.9
1.85V	376	346	300	238	199	162	118	81.7	66.9
1.83V	433	381	320	260	210	169	119	83.4	67.5
1.80V	478	435	354	283	219	175	120	83.6	68.2
1.75V	498	470	410	304	225	177	121	84.0	69.4
1.70V	535	510	444	317	231	179	122	84.5	70.2
1.65V	613	565	476	332	235	180	123	84.9	70.8
1.60V	654	607	495	337	236	181	124	85.6	71.4

### PARAMETERS FOR SOLAR & WIND APPLICATIONS

#### Long time discharge capacity for Solar & Wind applications

Capacity	C <sub>20</sub> (Ah)	C <sub>24</sub> (Ah)	C <sub>48</sub> (Ah)	C <sub>72</sub> (Ah)	C <sub>100</sub> (Ah)	C <sub>120</sub> (Ah)	C <sub>240</sub> (Ah)
OPzV2-350	380	396	427	441	446	452	464
Final Voltage	1.80V						

#### Solar & Wind applications parameters settings

Over voltage disconnect:	2.45±0.01V/cell @ 20~25°C
Regulation/equalize voltage:	2.40±0.01V/cell @ 20~25°C
Array reconnection voltage:	2.25±0.005V/cell @ 20~25°C
Float voltage setting:	2.27±0.005V/cell @ 20~25°C
Low voltage alarm voltage:	1.95±0.005V/cell @ 20~25°C
Low voltage disconnect:	1.90±0.005V/cell @ 20~25°C
Load reconnect voltage:	2.09±0.01V/cell @ 20~25°C
Temp. compensate coefficient:	-5mV/cell/°C

## CHARACTERISTICS

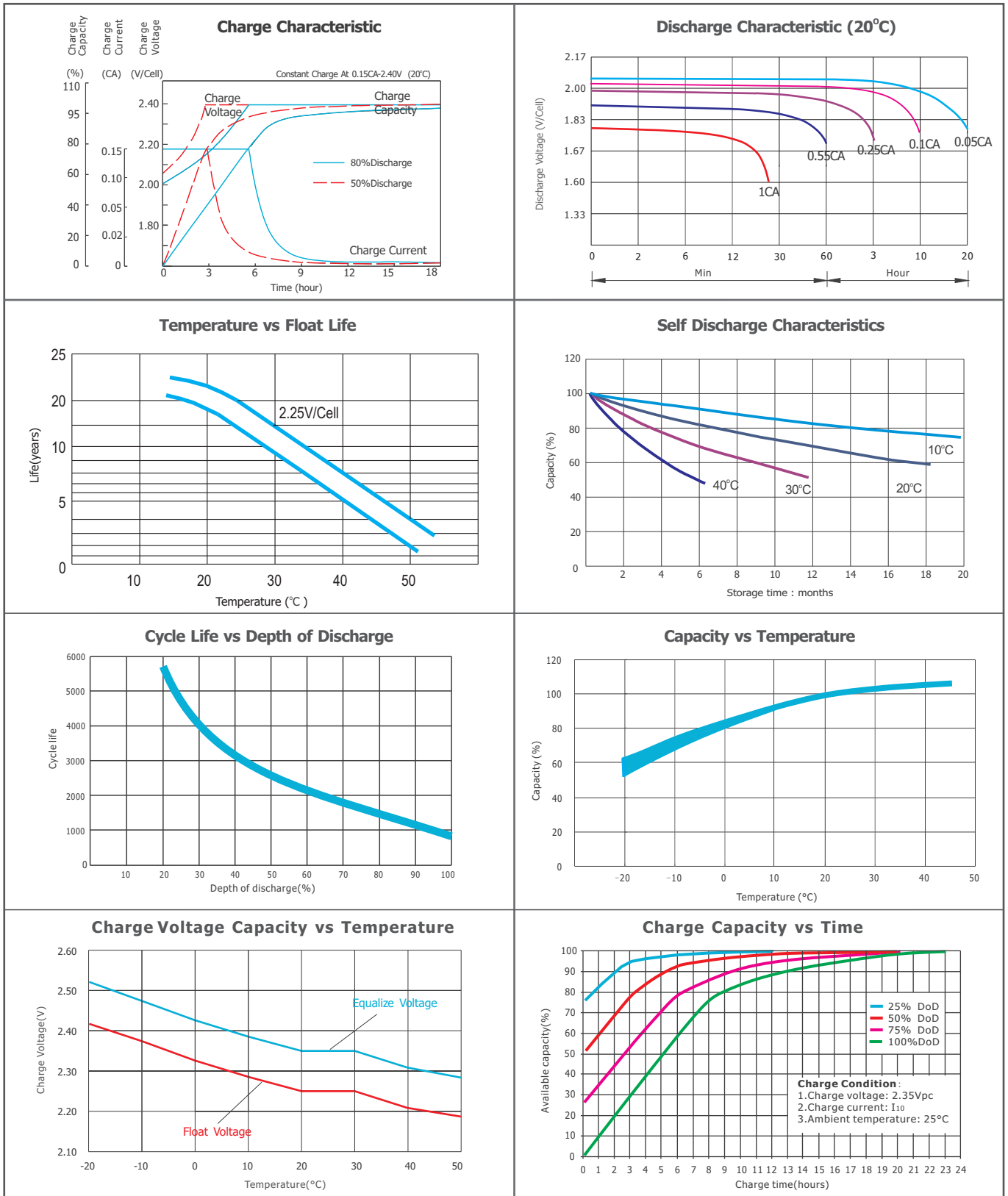

### FINAL VOLTAGE SETTINGS RECOMMENDED ACCORDING TO THE DISCHARGE CURRENT

Discharge Current I (A)	I < 0.05C	0.05C ≤ I < 0.08C	0.08C ≤ I < 0.2C	0.2C ≤ I < 0.6C	0.6C ≤ I < 1.0C	1C ≤ I ≤ 2C
Final of Voltage	≥1.90 Vpc	≥1.85 Vpc	≥1.80 Vpc	≥1.75 Vpc	≥1.7 Vpc	≥1.6 Vpc

### HEADQUARTERS AND SUBSIDIARIES:

BSB Power Company Limited (HQ)  
BSB Power Europe (France)

BSB Power Malaysia Sdn. Bhd  
PT. BSB Indonesia

BSB Power (Thailand) Co., Ltd  
BSB Power Company Pakistan Ltd