





2V TUBULAR GEL SERIES VRLA BATTERY

The OPzV series adopts an Immobilized Gel and Tubular Positive Plate technology. It offers high reliability and stable performance. By using die-casted positive grid and patented active material formula, it exceeds the DIN standard values and offer 20+ years design life in float service. It is very suitable for cyclic use under extreme operating conditions. This series is recommended for telecom outdoor applications, renewable energy systems and other harsh environment applications.

2 V voltage	150 Ah capacity	Tubular gel	20+ years design life
			



SPECIFICATIONS

Nominal Voltage (V)	2
Designed Floating Life (20°C)	20+ Years
Nominal Capacity (20°C)	150 Ah @ C ₁₀ (to 1.80Vpc)
Dimensions	L103mm×W206mm×H390mm
Approx. Weight	15.4 kg (34.0 lbs)
Terminal Type	Female Copper Insert M8 (torque:10~12N.m)
Internal Resistance	Approx. 1.15mOhm (fully charged @ 20°C)
Max. Charge Current	30 A
Max. Discharge Current (5S)	1000 A
Short Circuit Current	1700 A
Self Discharge	Approx. 2% per month @ 20°C
Ambient Temperature	Discharge: -40~65°C Charge: -30~65°C Storage: -25~45°C
Float Charge Voltage (20~25°C)	2.25-2.29V (-3mV / °C/ cell)
Equalize Charge Voltage (20~25°C)	2.35-2.40V (-5mV / °C/ cell)
Container Material	ABS(UL94-V0 optional)



Complied standards

- IEC 60896-21/22
- DIN40742
- IEC61427
- YD/T1360
- Eurobat guide, long life
- BS6290 part 4
- UL1989

DIMENSIONS

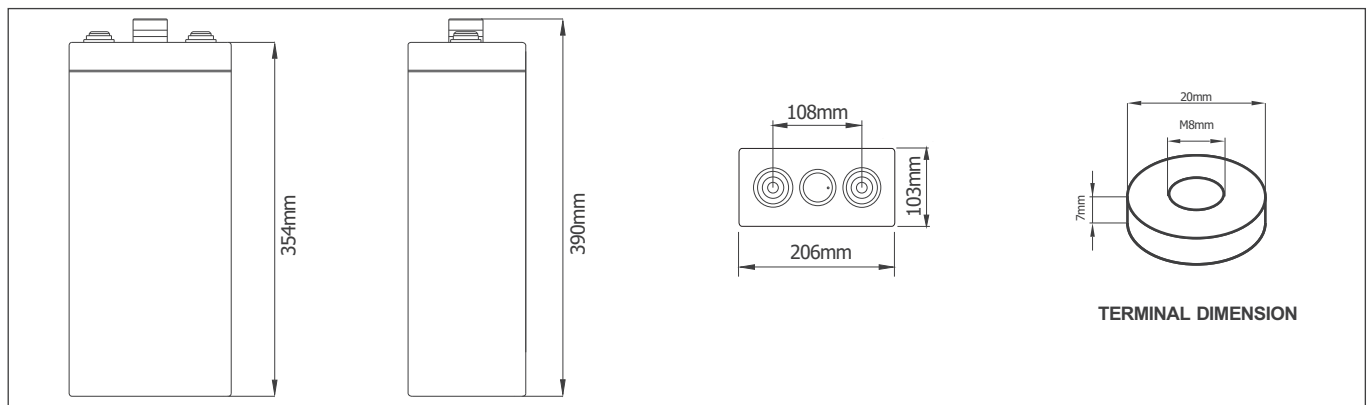

BATTERY DISCHARGE TABLE

Constant Current Discharge Characteristics: Amps (20°C)

F.V/Time	10m in	15m in	30m in	1h	2h	3h	5h	8h	10h
1.90V	55.0	53.5	50.0	42.0	35.8	30.0	22.2	15.9	13.1
1.87V	75.0	70.0	62.0	49.0	40.0	33.1	24.1	16.9	13.9
1.85V	86.2	79.0	68.0	53.5	44.1	35.6	25.7	17.7	14.4
1.83V	100	88.0	73.5	59.0	47.1	37.6	26.3	18.2	14.7
1.80V	112	102	82.3	65.0	49.7	39.4	26.8	18.5	15.0
1.75V	119	112	96.5	70.8	51.9	40.5	27.3	18.8	15.5
1.70V	130	123	106	74.8	53.9	41.3	27.8	19.1	15.8
1.65V	151	139	116	79.5	55.4	42.0	28.4	19.4	16.1
1.60V	165	152	123	82.0	56.6	42.8	29.0	19.7	16.4

Constant Power Discharge Characteristics: W/cell (20°C)

F.V/Time	10m in	15m in	30m in	1h	2h	3h	5h	8h	10h
1.90V	106	104	97.4	82.4	70.7	59.7	44.5	32.0	26.5
1.87V	142	133	119	94.6	78.2	65.1	47.9	33.7	27.8
1.85V	161	148	129	102	85.2	69.3	50.4	35.0	28.7
1.83V	186	163	137	111	90.0	72.4	51.0	35.8	28.9
1.80V	205	187	152	121	93.8	75.2	51.5	35.8	29.2
1.75V	214	202	176	130	96.6	76.1	51.8	36.0	29.8
1.70V	229	218	190	136	99.1	76.6	52.1	36.2	30.1
1.65V	263	242	204	142	101	77.1	52.6	36.4	30.4
1.60V	280	260	212	144	101	77.3	53.1	36.7	30.6

PARAMETERS FOR SOLAR & WIND APPLICATIONS

Long time discharge capacity for Solar & Wind applications

Capacity	C ₂₀ (Ah)	C ₂₄ (Ah)	C ₄₈ (Ah)	C ₇₂ (Ah)	C ₁₀₀ (Ah)	C ₁₂₀ (Ah)	C ₂₄₀ (Ah)
OPzV2-150	165	170	183	189	191	193	199
Final Voltage	1.80V						

Solar & Wind applications parameters settings

Over voltage disconnect:	2.45±0.01V/cell @ 20~25°C
Regulation/equalize voltage:	2.40±0.01V/cell @ 20~25°C
Array reconnection voltage:	2.25±0.005V/cell @ 20~25°C
Float voltage setting:	2.27±0.005V/cell @ 20~25°C
Low voltage alarm voltage:	1.95±0.005V/cell @ 20~25°C
Low voltage disconnect:	1.90±0.005V/cell @ 20~25°C
Load reconnect voltage:	2.09±0.01V/cell @ 20~25°C
Temp. compensate coefficient:	-5mV/cell/°C

CHARACTERISTICS

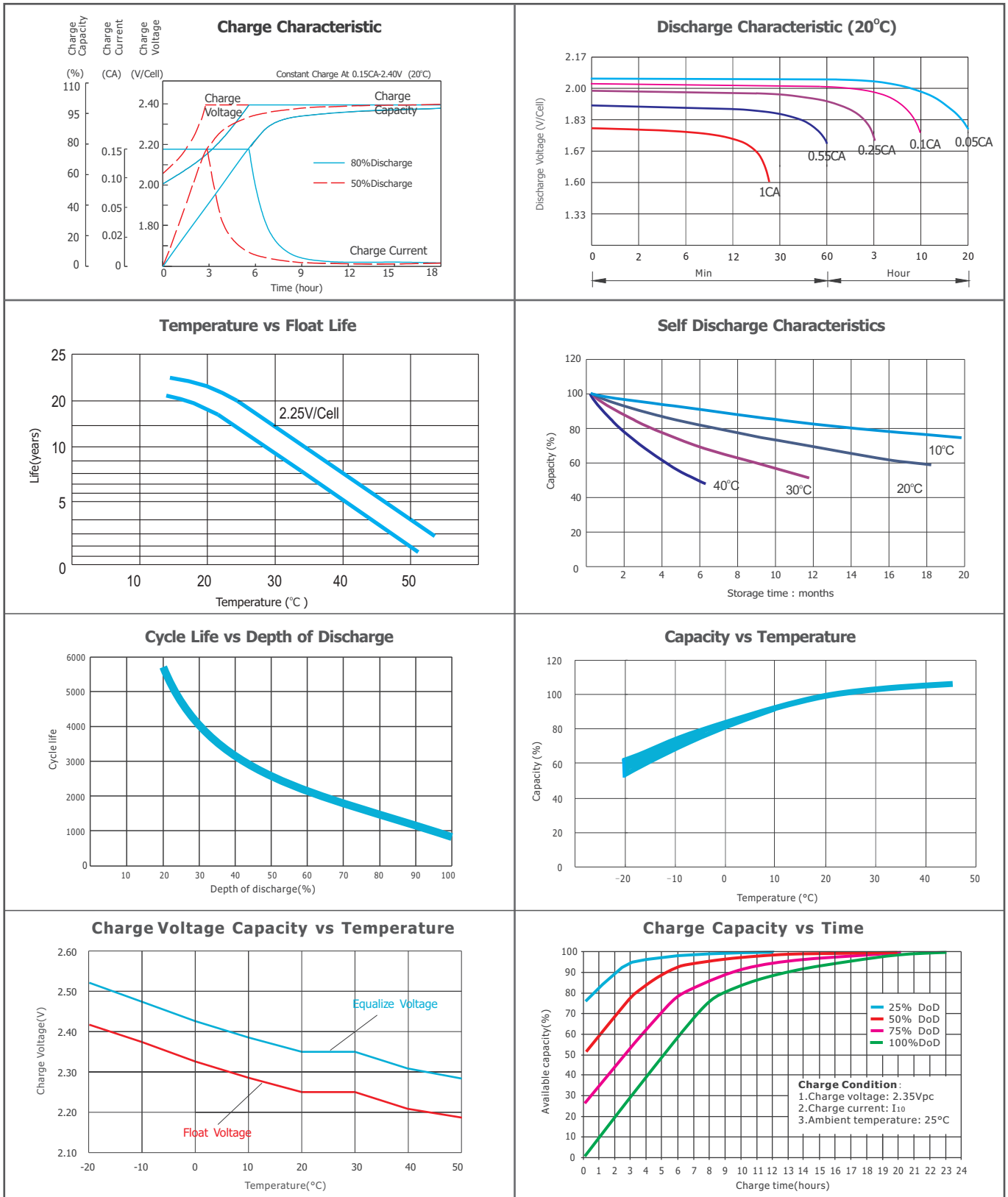

FINAL VOLTAGE SETTINGS RECOMMENDED ACCORDING TO THE DISCHARGE CURRENT

Discharge Current I (A)	I < 0.05C	0.05C ≤ I < 0.08C	0.08C ≤ I < 0.2C	0.2C ≤ I < 0.6C	0.6C ≤ I < 1.0C	1C ≤ I ≤ 2C
Final of Voltage	≥1.90 Vpc	≥1.85 Vpc	≥1.80 Vpc	≥1.75 Vpc	≥1.7 Vpc	≥1.6 Vpc

HEADQUARTERS AND SUBSIDIARIES:

BSB Power Company Limited (HQ)
BSB Power Europe (France)

BSB Power Malaysia Sdn. Bhd
PT. BSB Indonesia

BSB Power (Thailand) Co., Ltd
BSB Power Company Pakistan Ltd