

GENERAL SERIES VRLA BATTERY

GB series offers 5 years full maintenance free design life. With compact design and good reliability, this series is highly suited for security and alarm systems, UPS systems, emergency light systems and other small backup applications.



TECHNICAL SPECIFICATIONS

Nominal Voltage (V)	12 (6 cells per unit)
Designed Floating Life (20°C)	5 Years
Nominal Capacity (25°C)	1.3 Ah @ 20HR-rate (to 1.75Vpc)
Dimension (mm)	L97mm x W43mm x H58mm
Approx. Weight	0.58 kg (1.28 lbs)
Terminal Type	Fasten Tab F1
Internal Resistance	Approx. 0.08 Ohm (fully charged @ 25°C)
Max. Charge Current	0.39A
Max. Discharge Current (5S)	20 A
Short Circuit Current	150 A
Self Discharge	Approx. 3% per month @ 20°C
Ambient Temperature	Discharge: -15~55°C Charge: -15~45°C Storage: -15~45°C
Float Charge Voltage (20~25°C)	13.6-13.8V (-3mV/ cell/ °C)
Equalize and cycle Use Charge Voltage (20~25°C)	14.4-14.8V (-5mV/ cell / °C)
Container Material	ABS (UL94-V0 optional)



- Complied standards**
- IEC 61056
 - UL1989
 - JIS C8702
 - GB/T19639

BATTERY DIMENSIONS

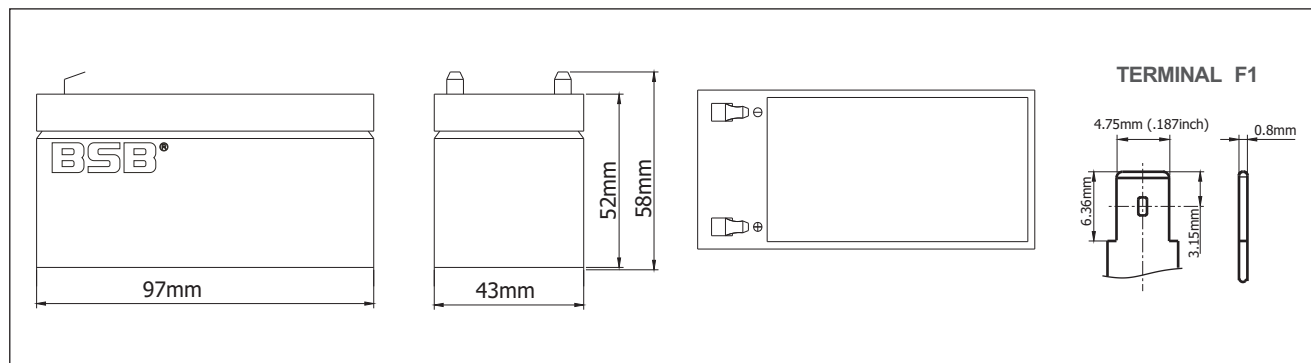

BATTERY DISCHARGE TABLE

Constant Current Discharge Characteristics: Amps (25°C)												
F.V/Time	5min	10min	15min	30min	1h	2h	3h	4h	5h	8h	10h	20h
1.60V	5.21	3.23	2.47	1.47	0.86	0.51	0.37	0.283	0.234	0.157	0.129	0.069
1.67V	4.84	3.12	2.38	1.43	0.85	0.50	0.36	0.279	0.231	0.156	0.127	0.068
1.70V	4.49	2.99	2.32	1.41	0.83	0.49	0.35	0.276	0.228	0.154	0.126	0.066
1.75V	4.10	2.85	2.26	1.38	0.82	0.48	0.34	0.273	0.225	0.152	0.124	0.065
1.80V	3.67	2.70	2.21	1.35	0.80	0.47	0.33	0.269	0.222	0.151	0.123	0.064
1.85V	3.24	2.54	2.15	1.32	0.79	0.46	0.32	0.266	0.220	0.149	0.121	0.062

Constant Power Discharge Characteristics: W/cell (25°C)												
F.V/Time	5min	10min	15min	30min	1h	2h	3h	4h	5h	8h	10h	20h
1.60V	9.17	5.81	4.50	2.71	1.59	0.96	0.69	0.537	0.445	0.303	0.249	0.134
1.67V	8.63	5.67	4.38	2.66	1.58	0.95	0.68	0.532	0.443	0.301	0.247	0.132
1.70V	8.11	5.48	4.31	2.64	1.57	0.94	0.67	0.530	0.440	0.300	0.246	0.131
1.75V	7.49	5.30	4.24	2.60	1.56	0.93	0.66	0.529	0.438	0.299	0.245	0.129
1.80V	6.80	5.06	4.18	2.57	1.54	0.92	0.65	0.526	0.436	0.298	0.244	0.127
1.85V	6.11	4.83	4.11	2.55	1.53	0.91	0.64	0.525	0.436	0.296	0.242	0.125

CHARACTERISTICS

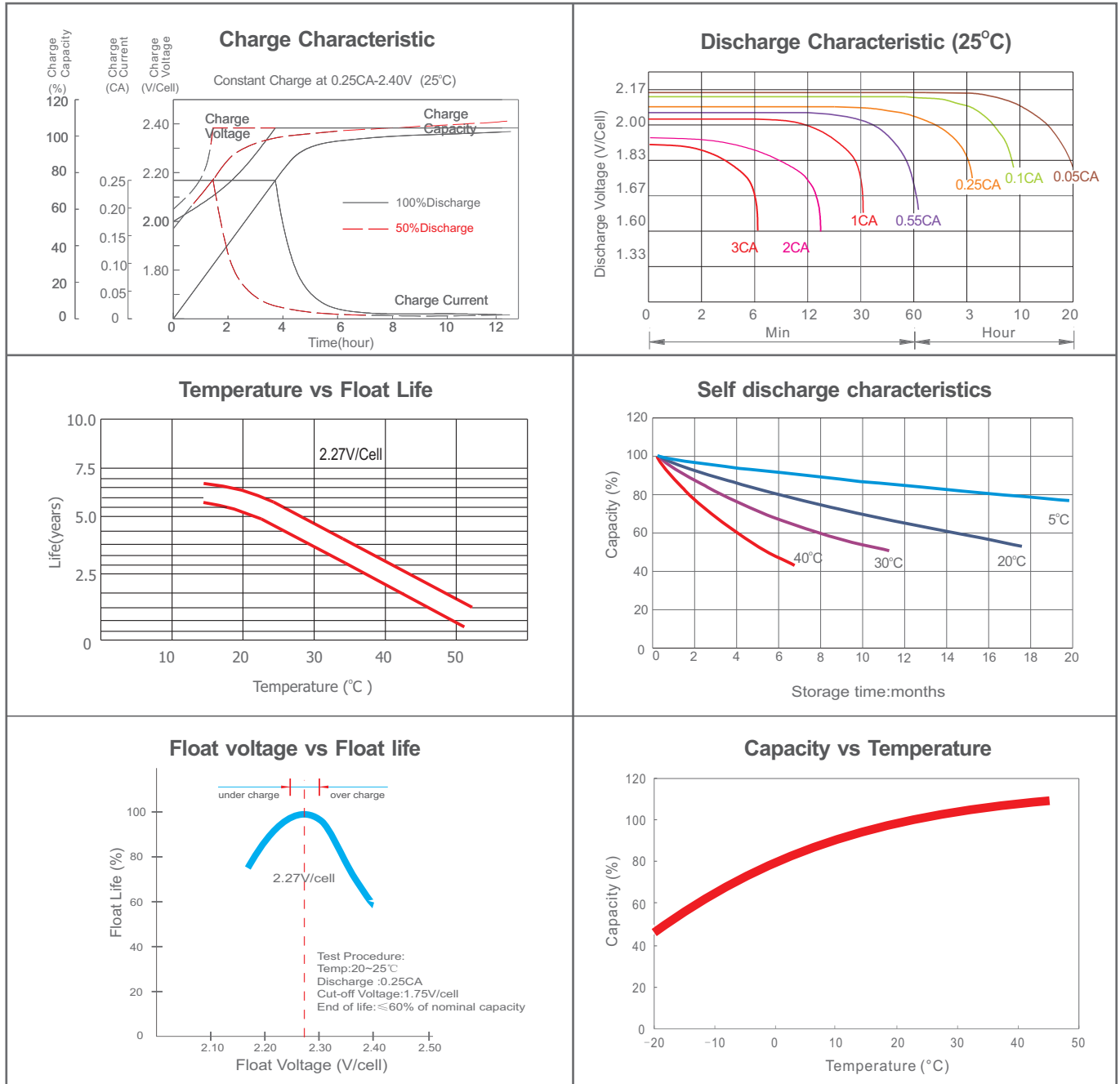

FINAL VOLTAGE SETTINGS RECOMMENDED ACCORDING TO THE DISCHARGE CURRENT

Discharge Current I (A)	$I \leq 0.08C$	$0.08C \leq I < 0.2C$	$0.2C \leq I < 0.6C$	$0.6C \leq I < 1.0C$	$I \geq 1.0C$
Final of Voltage	$\geq 1.85V_{pc}$	$\geq 1.80V_{pc}$	$\geq 1.75V_{pc}$	$\geq 1.70V_{pc}$	$\geq 1.60V_{pc}$

HEADQUARTERS AND SUBSIDIARIES

BSB Power Company Limited (HQ)
 BSB Power Europe (France)
 BSB Power Malaysia Sdn. Bhd
 PT. BSB Indonesia
 BSB Power (Thailand) Co., Ltd
 BSB Power Company Pakistan Ltd

