

## DURATION SERIES VRLA BATTERY

By combining up-to-date DCP-II formula in the positive plates and enhanced electrolyte for VRLA, BSB created an innovative range of DC batteries. This range features deep cycling use with higher cyclic life when compared with the standard Duration range. This series is highly suited to cyclic applications such as outdoor applications, small RE systems and electric vehicles.

**12 V** voltage    **90Ah** capacity    **AGM** tech    **Enhanced deep cycling**



### TECHNICAL SPECIFICATIONS

Nominal Voltage (V)	12 (6 cells per unit)
Designed Floating Life (20°C)	12 Years
Nominal Capacity (20°C)	90 Ah @ 10HR-rate (to 1.80Vpc)
Dimension (mm)	L306mm x W169mm x H216mm
Approx. Weight	25.5 kg (56.2 lbs)
Terminal Type	Female Copper Insert M6 (torque:6~7N.m)
Internal Resistance	Approx. 0.0052 Ohm (fully charged @ 20°C)
Max. Charge Current	22.5A
Max. Discharge Current (5S)	720 A
Short Circuit Current	2300 A
Self Discharge	Approx. 3% per month @ 20°C
Ambient Temperature	Discharge: -20~60°C Charge: -20~60°C Storage: -20~45°C
Float Charge Voltage (20~25°C)	13.6-13.8V (-3mV/ cell/ °C)
Equalize and cycle Use Charge Voltage (20~25°C)	14.4-14.8V (-5mV/ cell / °C)
Container Material	ABS (UL94-V0 optional)



#### Complied standards

- IEC 60896-21/22
- UL1989
- JIS C8704
- GB/T19638

### BATTERY DIMENSIONS

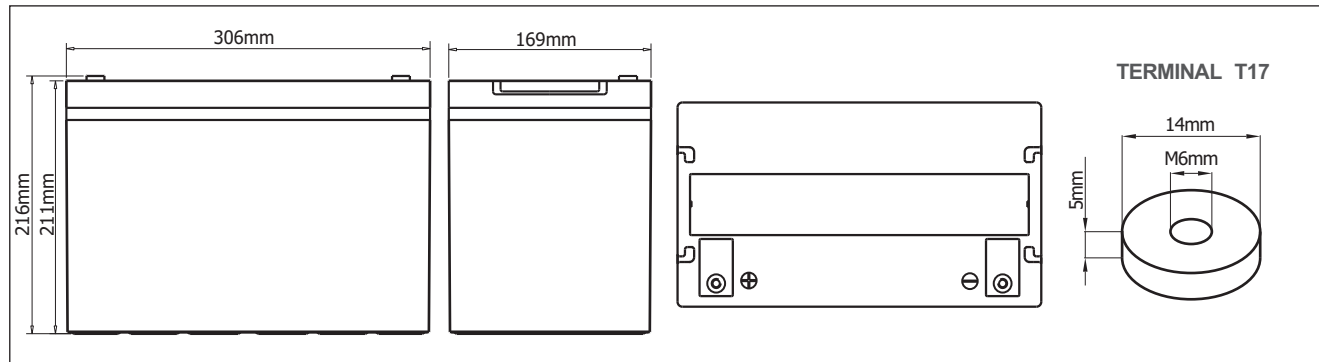

### BATTERY DISCHARGE TABLE

Constant Current Discharge Characteristics: Amps (25°C)											
F.V/Tim e	10 m in	15 m in	30 m in	1 h	2 h	3 h	4 h	5 h	8 h	10 h	20 h
1.60 V	191	158	97.3	59.6	35.0	25.2	20.3	16.9	11.6	9.55	5.14
1.67 V	176	149	93.0	58.1	34.4	24.9	20.1	16.7	11.4	9.42	5.02
1.70 V	160	141	89.5	56.7	33.9	24.7	19.9	16.6	11.3	9.31	4.91
1.75 V	149	131	86.4	55.5	33.3	24.3	19.6	16.4	11.1	9.18	4.82
1.80 V	135	122	82.6	53.7	32.6	23.8	19.2	16.0	10.9	9.00	4.72
1.85 V	122	111	77.9	51.4	31.3	23.0	18.6	15.6	10.6	8.77	4.61

Constant Power Discharge Characteristics: W/cell (25°C)											
F.V/Tim e	10 m in	15 m in	30 m in	1 h	2 h	3 h	4 h	5 h	8 h	10 h	20 h
1.60 V	344	288	180	111	65.7	47.7	38.5	32.2	22.2	18.4	10.0
1.67 V	320	273	173	109	64.9	47.4	38.3	32.1	22.1	18.3	9.82
1.70 V	294	261	168	107	64.6	47.2	38.2	32.0	22.0	18.2	9.67
1.75 V	276	245	163	106	64.0	46.8	38.1	31.8	21.8	18.1	9.55
1.80 V	254	230	157	103	63.2	46.3	37.5	31.3	21.5	17.9	9.43
1.85 V	231	212	150	100	61.3	45.2	36.7	30.8	21.2	17.5	9.27

## CHARACTERISTICS

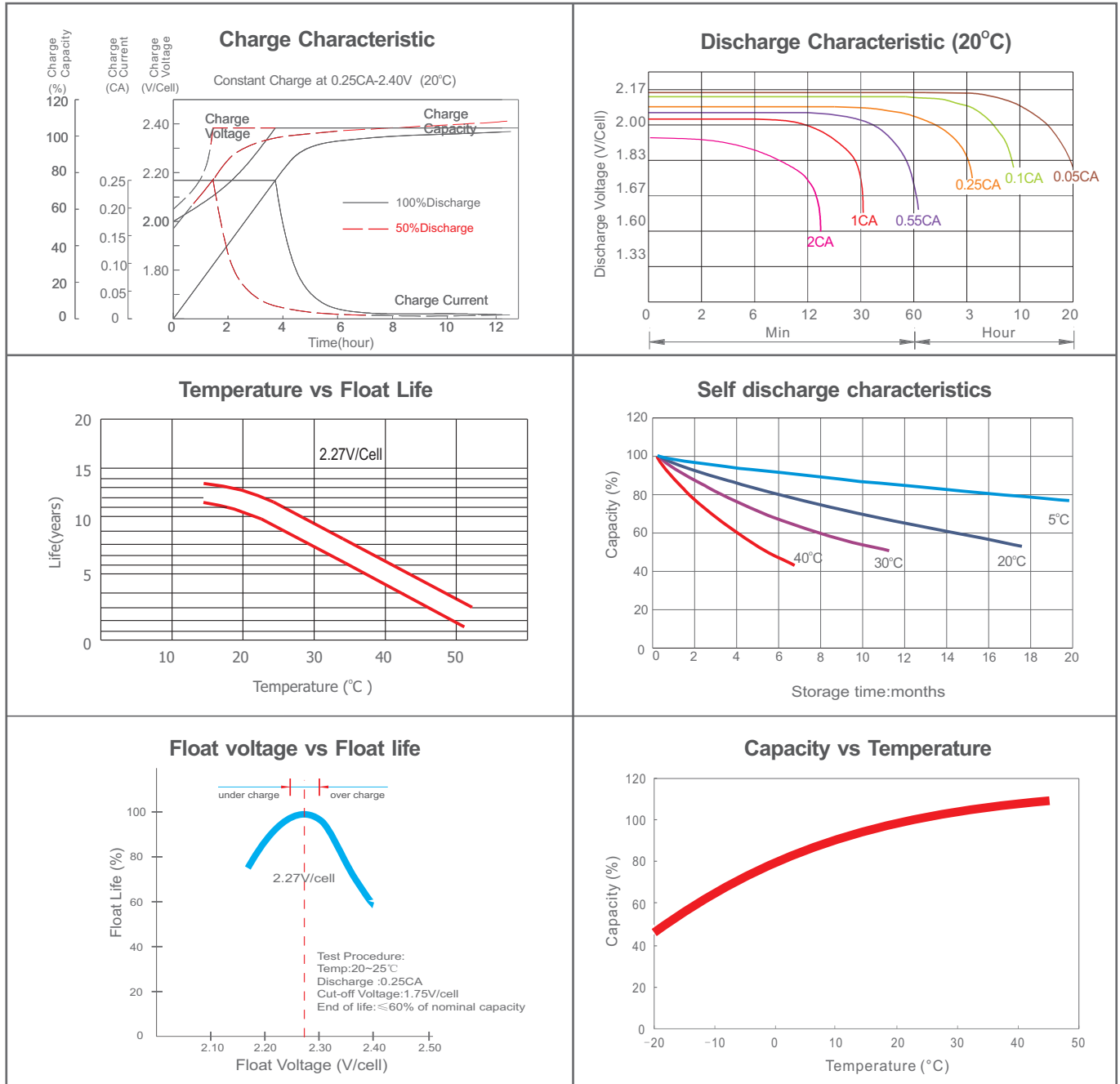

## FINAL VOLTAGE SETTINGS RECOMMENDED ACCORDING TO THE DISCHARGE CURRENT

Discharge Current I (A)	$I \leq 0.08C$	$0.08C \leq I < 0.2C$	$0.2C \leq I < 0.6C$	$0.6C \leq I < 1.0C$	$I \geq 1.0C$
Final of Voltage	$\geq 1.85V_{pc}$	$\geq 1.80V_{pc}$	$\geq 1.75V_{pc}$	$\geq 1.70V_{pc}$	$\geq 1.60V_{pc}$

## HEADQUARTERS AND SUBSIDIARIES

BSB Power Company Limited (HQ)  
 BSB Power Europe (France)  
 BSB Power Malaysia Sdn. Bhd  
 PT. BSB Indonesia  
 BSB Power (Thailand) Co., Ltd  
 BSB Power Company Pakistan Ltd

