

DURATION SERIES VRLA BATTERY

By combining up-to-date DCP-II formula in the positive plates and enhanced electrolyte for VRLA, BSB created an innovative range of DC batteries. This range features deep cycling use with higher cyclic life when compared with the standard Duration range. This series is highly suited to cyclic applications such as outdoor applications, small RE systems and electric vehicles.

12 V voltage **20Ah** capacity **AGM** tech **Enhanced deep cycling**



TECHNICAL SPECIFICATIONS

Nominal Voltage (V)	12 (6 cells per unit)
Designed Floating Life (20°C)	5 Years
Nominal Capacity (25°C)	20 Ah @ 20HR-rate (to 1.75Vpc)
Dimension (mm)	L181mm x W76mm x H167mm
Approx. Weight	5.8 kg (12.8 lbs)
Terminal Type	Terminal T5
Internal Resistance	Approx. 0.012 Ohm (fully charged @ 25°C)
Max. Charge Current	6 A
Max. Discharge Current (5S)	300 A
Short Circuit Current	1000 A
Self Discharge	Approx. 3% per month @ 20°C
Ambient Temperature	Discharge: -15~55°C Charge: -15~45°C Storage: -15~45°C
Float Charge Voltage (20~25°C)	13.6-13.8V (-3mV/ cell/ °C)
Equalize and cycle Use Charge Voltage (20~25°C)	14.4-14.8V (-5mV/ cell / °C)
Container Material	ABS (UL94-V0 optional)



ISO9001 ISO14001



Complied standards

- IEC 61056
- UL1989
- JIS C8707
- GB/T19639

BATTERY DIMENSIONS

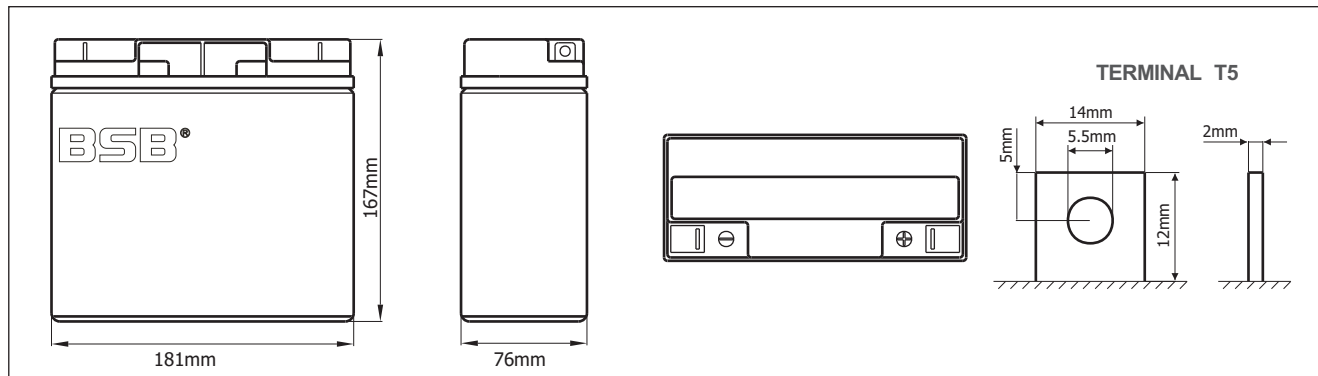

BATTERY DISCHARGE TABLE

Constant Current Discharge Characteristics: Amps (25°C)											
F.V/Time	10 m in	15 m in	30 m in	1h	2h	3h	4h	5h	8h	10h	20h
1.60V	42.9	32.8	19.5	12.3	7.72	5.51	4.36	3.60	2.42	1.98	1.06
1.67V	41.5	31.7	19.0	12.1	7.63	5.46	4.29	3.56	2.40	1.96	1.04
1.70V	39.7	30.9	18.7	11.9	7.55	5.41	4.24	3.51	2.37	1.93	1.02
1.75V	37.9	30.1	18.3	11.7	7.45	5.35	4.20	3.46	2.35	1.91	1.00
1.80V	35.9	29.4	18.0	11.5	7.34	5.27	4.14	3.42	2.32	1.89	0.98
1.85V	33.8	28.6	17.6	11.3	7.24	5.21	4.10	3.39	2.29	1.87	0.95

Constant Power Discharge Characteristics: W/cell (25°C)											
F.V/Time	10 m in	15 m in	30 m in	1h	2h	3h	4h	5h	8h	10h	20h
1.60V	85.8	66.4	40.0	24.0	14.6	10.5	8.26	6.84	4.66	3.83	2.06
1.67V	83.7	64.6	39.3	23.9	14.5	10.4	8.19	6.81	4.63	3.80	2.04
1.70V	80.9	63.6	38.9	23.7	14.4	10.3	8.15	6.78	4.61	3.79	2.01
1.75V	78.2	62.6	38.4	23.5	14.3	10.2	8.13	6.74	4.61	3.77	1.99
1.80V	74.8	61.7	38.0	23.2	14.2	10.1	8.10	6.71	4.59	3.75	1.95
1.85V	71.3	60.8	37.6	23.1	14.1	10.0	8.08	6.70	4.56	3.73	1.92

CHARACTERISTICS

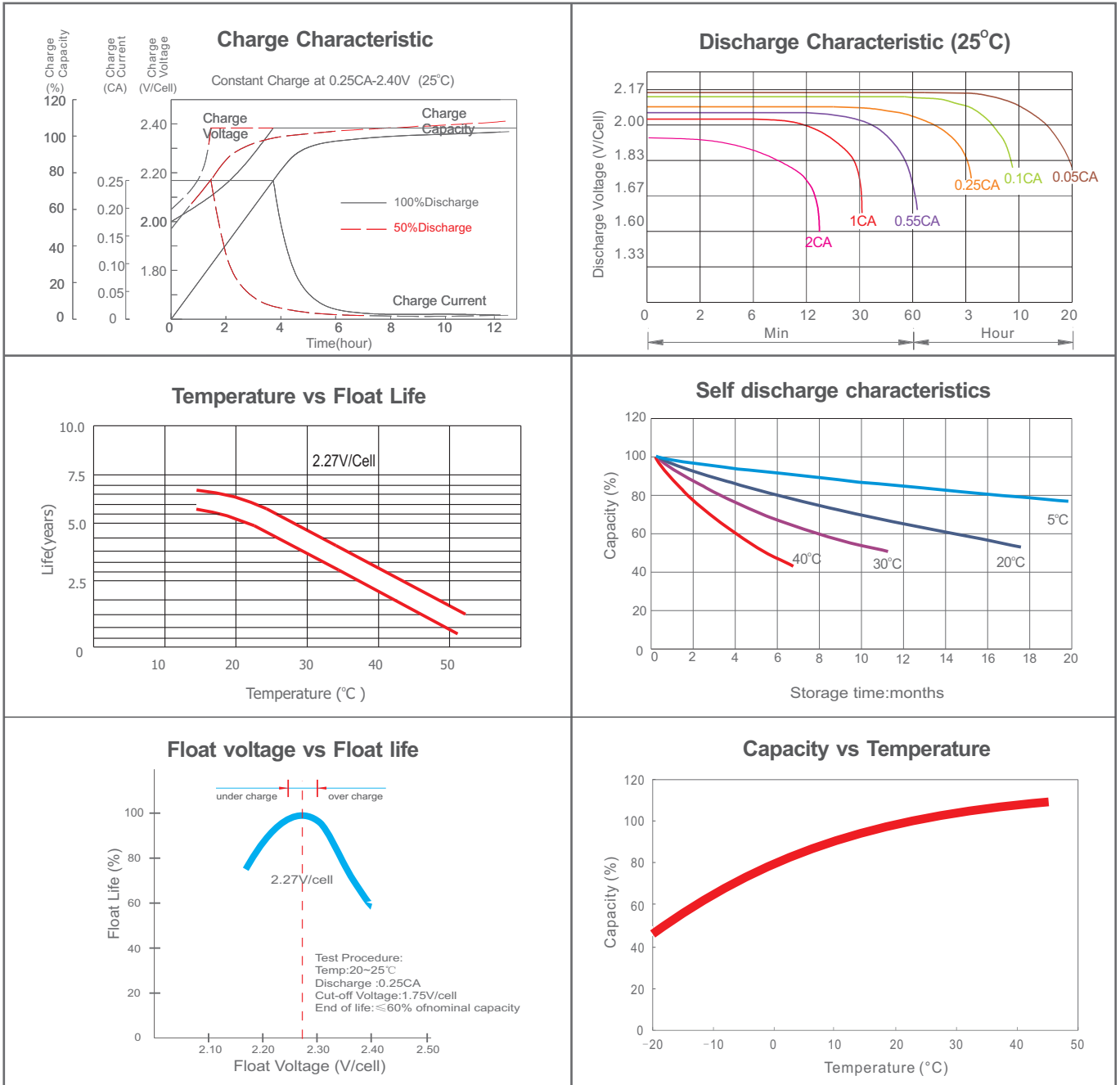

FINAL VOLTAGE SETTINGS RECOMMENDED ACCORDING TO THE DISCHARGE CURRENT

Discharge Current I (A)	$I \leq 0.08C$	$0.08C \leq I < 0.2C$	$0.2C \leq I < 0.6C$	$0.6C \leq I < 1.0C$	$I \geq 1.0C$
Final of Voltage	$\geq 1.85V_{pc}$	$\geq 1.80V_{pc}$	$\geq 1.75V_{pc}$	$\geq 1.7V_{pc}$	$\geq 1.6V_{pc}$

HEADQUARTERS AND SUBSIDIARIES

- BSB Power Company Limited (HQ)
- BSB Power Europe (France)
- BSB Power Malaysia Sdn. Bhd
- PT. BSB Indonesia
- BSB Power (Thailand) Co., Ltd
- BSB Power Company Pakistan Ltd

