

DURATION SERIES VRLA BATTERY

By combining a newly developed corrosion resistance alloy and advanced curing process, BSB created a range of long life batteries - Duration range. The range features top termination and offers 12 years design life. This battery series is highly suited to UPS systems, switchgear, CATV and telecommunication systems applications.



TECHNICAL SPECIFICATIONS

Nominal Voltage (V)	12 (6 cells per unit)
Designed Floating Life (20°C)	12 Years
Nominal Capacity (20°C)	40 Ah @ 10HR-rate (to 1.80Vpc)
Dimension (mm)	L197mm x W165mm x H170mm
Approx. Weight	13 kg (28.7 lbs)
Terminal Type	Female Copper Insert M6 (torque:6~7N.m)
Internal Resistance	Approx. 0.0095 Ohm (fully charged @ 20°C)
Max. Charge Current	10A
Max. Discharge Current (5S)	400 A
Short Circuit Current	1260 A
Self Discharge	Approx. 3% per month @ 20°C
Ambient Temperature	Discharge: -20~60°C Charge: -20~60°C Storage: -20~45°C
Float Charge Voltage (20~25°C)	13.6-13.8V (-3mV/ cell/ °C)
Equalize and cycle Use Charge Voltage (20~25°C)	14.4-14.8V (-5mV/ cell / °C)
Container Material	ABS (UL94-V0 optional)



Complied standards

- IEC 60896-21/22
- UL1989
- JIS C8704
- GB/T19639

BATTERY DIMENSIONS

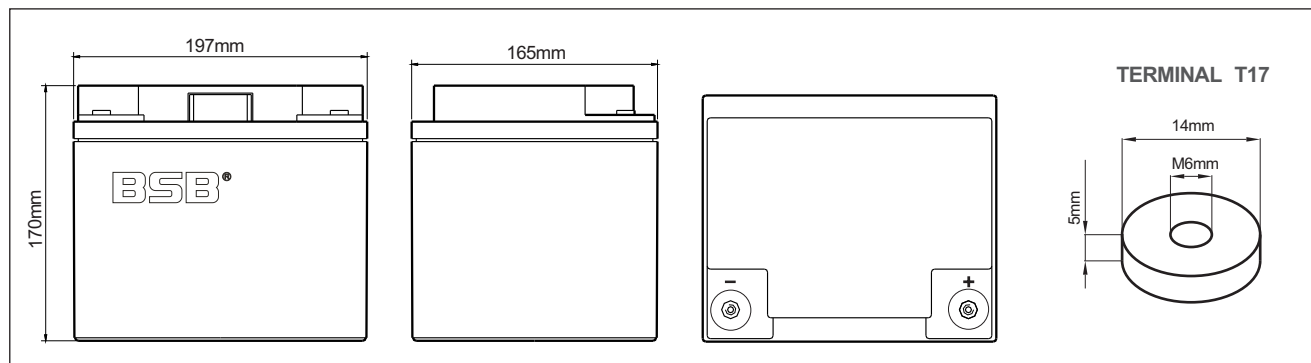

BATTERY DISCHARGE TABLE

Constant Current Discharge Characteristics: Amps (25°C)												
F.V/Time	5min	10min	15min	30min	1h	2h	3h	4h	5h	8h	10h	20h
1.60V	120	88.5	73.1	45.0	27.0	15.7	11.3	9.04	7.53	5.14	4.24	2.28
1.67V	107	81.6	68.9	43.0	26.3	15.4	11.2	8.92	7.42	5.07	4.19	2.23
1.70V	95.6	74.1	65.1	41.4	25.7	15.2	11.1	8.83	7.37	5.01	4.14	2.18
1.75V	83.1	68.9	60.4	40.0	25.2	15.0	10.9	8.73	7.27	4.94	4.08	2.14
1.80V	73.5	62.6	56.4	38.2	24.4	14.6	10.7	8.52	7.10	4.83	4.00	2.10
1.85V	62.9	56.4	51.4	36.1	23.3	14.1	10.3	8.28	6.93	4.72	3.90	2.05

Constant Power Discharge Characteristics: W/cell (25°C)												
F.V/Time	5min	10min	15min	30min	1h	2h	3h	4h	5h	8h	10h	20h
1.60V	211	159	133	83.2	50.4	29.5	21.4	17.1	14.3	9.88	8.19	4.43
1.67V	191	148	127	80.0	49.4	29.2	21.3	17.0	14.3	9.81	8.14	4.36
1.70V	173	136	121	77.6	48.6	29.0	21.2	17.0	14.2	9.76	8.09	4.30
1.75V	152	128	113	75.5	47.9	28.7	21.0	16.9	14.2	9.70	8.04	4.24
1.80V	136	118	107	72.9	46.8	28.4	20.8	16.7	13.9	9.55	7.95	4.19
1.85V	118	107	98.1	69.5	45.2	27.5	20.3	16.3	13.7	9.40	7.79	4.12

CHARACTERISTICS

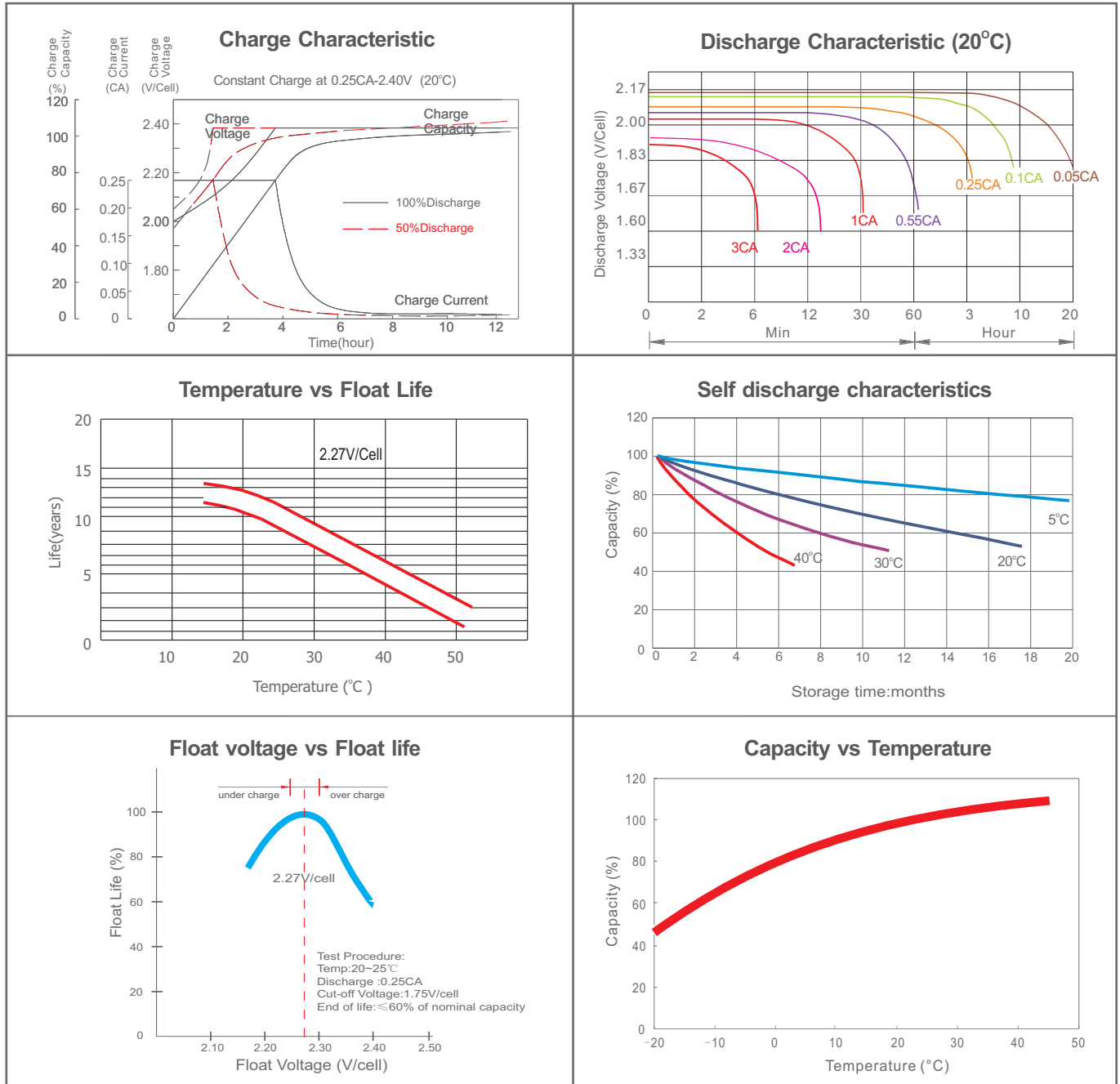

FINAL VOLTAGE SETTINGS RECOMMENDED ACCORDING TO THE DISCHARGE CURRENT

Discharge Current I (A)	$I \leq 0.08C$	$0.08C \leq I < 0.2C$	$0.2C \leq I < 0.6C$	$0.6C \leq I < 1.0C$	$I \geq 1.0C$
Final of Voltage	$\geq 1.85V_{pc}$	$\geq 1.80V_{pc}$	$\geq 1.75V_{pc}$	$\geq 1.70V_{pc}$	$\geq 1.60V_{pc}$

HEADQUARTERS AND SUBSIDIARIES

BSB Power Company Limited (HQ)
 BSB Power Europe (France)
 BSB Power Malaysia Sdn. Bhd
 PT. BSB Indonesia
 BSB Power (Thailand) Co., Ltd
 BSB Power Company Pakistan Ltd

