

WP5-12B 12Volt 5Ah

Specifications

Nominal Voltage(V) **12V**

Nominal Capacity

20 hour rate	(0.25A to 10.50V)	5Ah
10 hour rate	(0.475A to 10.50V)	4.75Ah
5 hour rate	(0.85A to 10.20V)	4.25Ah
1 C	(5A to 9.60V)	2.67Ah
3 C	(15A to 9.60V)	1.75Ah

Weight **Approx. 1.62kg(3.56Lbs.)**

Internal Resistance (at 1KHz) **Approx. 34 mΩ**

Maximum Discharge Current for

5 seconds: **75A**

Charging Methods at 25°C (77°F)

Cycle use:

Charging Voltage **14.4 to 15.0V**

Coefficient **-5.0mV/°C/cell**

Maximum Charging Current : **1.5A**

Standby use:

Float Charging Voltage **13.5 to 13.8V**

Coefficient **-3.0mV/°C/cell**

Operating Temperature Range

Charge **-15°C (5°F) to 40°C (104°F)**

Discharge **-15°C (5°F) to 50°C (122°F)**

Storage **-15°C (5°F) to 40°C (104°F)**

Charge Retention (shelf life) at 20°C (68°F)

1 month	92%
3 month	90%
6 month	80%

Case Material **ABS**

(Option: UL94 HB & UL94 V-0 flame retardant)

Terminal **F1 or F2 (Faston Tab 187 or 250)**



Dimensions

mm(inch)

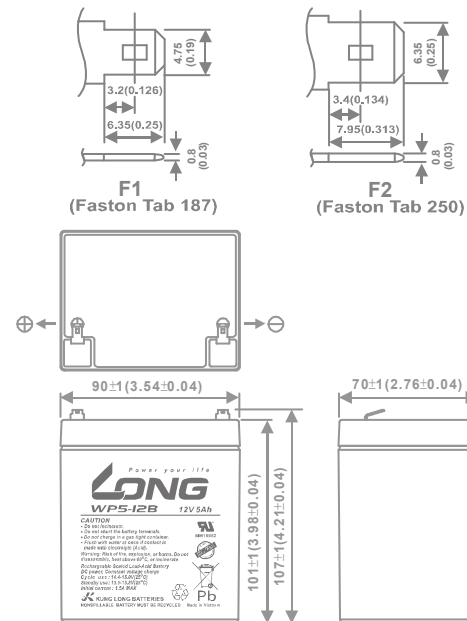

(V) FOR 12V BATTERY Discharge Time VS. Discharge Current (25°C)

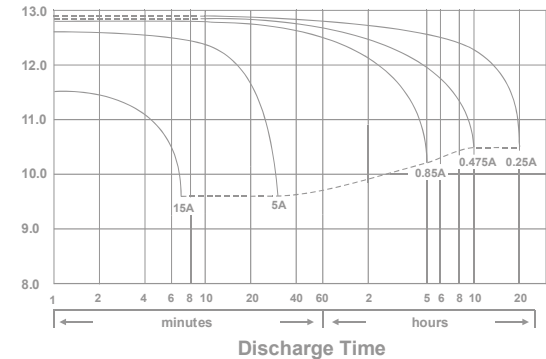

Effect of Temperature on Capacity 25°C(77°F)

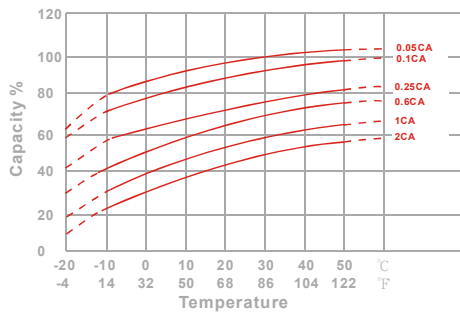

Capacity Retention Characteristic

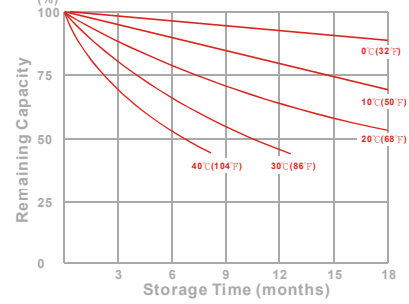

Trickle (or float) Service Life

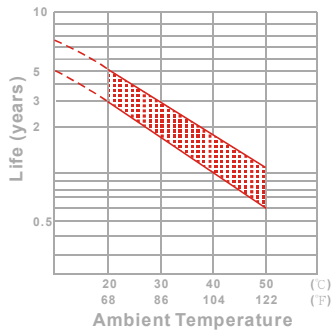

Cycle Service Life

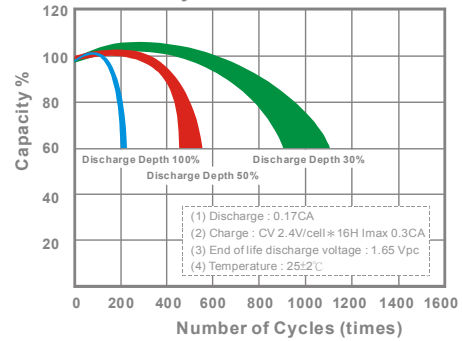

- PERFORMANCE DATA

Discharge Rates in Watts to Various End Voltages at 25°C(77°F)

End Voltage		1.85V	1.80V	1.75V	1.70V	1.67V	1.65V	1.60V
Time								
5	min	136	154	167	179	184	190	197
10	min	98.5	112	120	126	128	131	134
15	min	79.5	88.7	92.1	94.9	95.7	96.6	97.8
30	min	46.7	52.4	54.5	56.6	57.2	57.9	58.6
60	min	26.3	29.7	31.9	33.7	34.1	34.7	35.2
120	min	16.2	17.8	18.6	19.2	19.5	19.9	20.3
180	min	12.7	13.8	14.4	14.8	15.0	15.3	15.6
240	min	10.3	11.1	11.6	11.9	12.1	12.2	12.4
300	min	9.16	9.81	10.1	10.3	10.4	10.5	10.7
600	min	6.12	6.47	6.62	6.74	6.79	6.85	6.92
1200	min	2.88	3.11	3.23	3.31	3.33	3.37	3.41

- Discharge Rates in Amperes to Various End Voltages at 25°C(77°F)

End Voltage		1.85V	1.80V	1.75V	1.70V	1.67V	1.65V	1.60V
Time								
5	min	14.9	17.0	18.3	18.8	19.0	19.2	19.4
10	min	10.0	11.3	11.6	11.8	11.9	12.0	12.1
15	min	7.21	7.83	8.31	8.53	8.58	8.65	8.74
30	min	4.36	4.82	4.97	5.11	5.15	5.21	5.26
60	min	2.53	2.78	2.89	2.97	2.99	3.02	3.05
120	min	1.42	1.54	1.62	1.65	1.66	1.67	1.69
180	min	1.14	1.21	1.23	1.25	1.26	1.27	1.28
240	min	0.889	0.948	0.973	0.996	1.00	1.01	1.02
300	min	0.808	0.839	0.852	0.863	0.867	0.872	0.878
600	min	0.458	0.480	0.495	0.503	0.507	0.511	0.515
1200	min	0.231	0.245	0.257	0.265	0.268	0.272	0.276

All data on the spec. sheet is an average value:

The tolerance range : $X < 6\text{min}$ (+15%~-15%), $6\text{min} \leq X < 10\text{min}$ (+12%~-12%), $10\text{min} \leq X < 60\text{min}$ (+8%~-8%), $X \geq 60\text{min}$ (+5%~-5%)