

## 2V TUBULAR GEL SERIES VRLA BATTERY

The OPzV series adopts an Immobilized Gel and Tubular Positive Plate technology. It offers high reliability and stable performance. By using die-casted positive grid and patented active material formula, it exceeds the DIN standard values and offer 20+ years design life in float service. It is very suitable for cyclic use under extreme operating conditions. This series is recommended for telecom outdoor applications, renewable energy systems and other harsh environment applications.

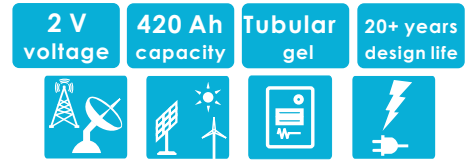

### SPECIFICATIONS

Nominal Voltage (V)	2
Designed Floating Life (20°C)	20+ Years
Nominal Capacity (20°C)	420 Ah @ C <sub>10</sub> (to 1.80Vpc)
Dimensions	L145mm×W206mm×H506mm
Approx. Weight	32.5 kg (71.7 lbs)
Terminal Type	Female Copper Insert M8 (torque:10~12N.m)
Internal Resistance	Approx. 0.70mOhm (fully charged @ 20°C)
Max. Charge Current	84 A
Max. Discharge Current (5S)	1500 A
Short Circuit Current	3400 A
Self Discharge	Approx. 2% per month @ 20°C
Ambient Temperature	Discharge: -40~65°C Charge: -30~65°C Storage: -25~45°C
Float Charge Voltage (20~25°C)	2.25-2.29V (-3mV / °C/ cell)
Equalize Charge Voltage (20~25°C)	2.35-2.40V (-5mV / °C/ cell)
Container Material	ABS(UL94-V0 optional)



### Complied standards

- IEC 60896-21/22
- DIN40742
- IEC61427
- YD/T1360
- Eurobat guide, long life
- BS6290 part 4
- UL1989

### DIMENSIONS

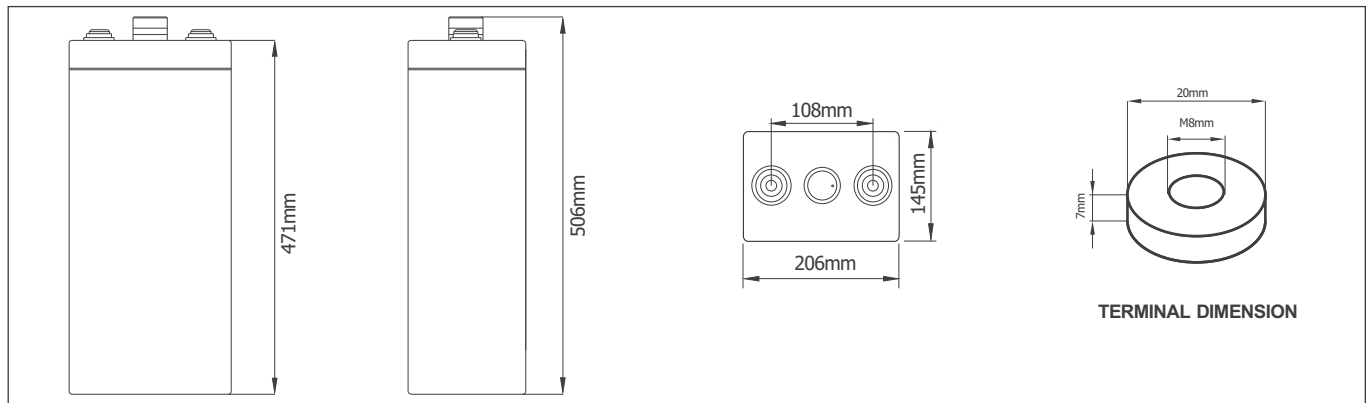

### BATTERY DISCHARGE TABLE

#### Constant Current Discharge Characteristics: Amps (20°C)

F.V/Tim e	10m in	15m in	30min	1h	2h	3h	5h	8h	10h
1.90V	154	150	140	118	100	84.0	62.2	44.5	36.8
1.87V	210	196	174	137	112	92.6	67.5	47.3	38.9
1.85V	241	221	190	150	123	100	71.8	49.4	40.4
1.83V	281	246	206	165	132	105	73.5	51.0	41.2
1.80V	315	286	230	182	139	110	75.0	51.7	42.0
1.75V	334	314	270	198	145	113	76.4	52.5	43.3
1.70V	363	344	297	209	151	116	77.7	53.3	44.1
1.65V	424	388	323	223	155	118	79.4	54.2	44.9
1.60V	462	426	343	230	158	120	81.1	55.2	45.8

#### Constant Power Discharge Characteristics: W/cell (20°C)

F.V/Tim e	10m in	15m in	30min	1h	2h	3h	5h	8h	10h
1.90V	297	290	273	231	198	167	125	89.5	74.3
1.87V	398	373	333	265	219	182	134	94.4	77.9
1.85V	451	415	360	286	238	194	141	98.0	80.3
1.83V	519	457	385	312	252	203	143	99.0	81.0
1.80V	573	522	425	339	263	210	144	100	81.8
1.75V	598	564	491	364	271	213	145	101	83.3
1.70V	642	611	532	380	278	215	146	102	84.3
1.65V	736	678	571	399	282	216	147	103	85.0
1.60V	785	729	594	404	284	217	149	104	85.7

### PARAMETERS FOR SOLAR & WIND APPLICATIONS

#### Long time discharge capacity for Solar & Wind applications

Capacity	C <sub>20</sub> (Ah)	C <sub>24</sub> (Ah)	C <sub>48</sub> (Ah)	C <sub>72</sub> (Ah)	C <sub>100</sub> (Ah)	C <sub>120</sub> (Ah)	C <sub>240</sub> (Ah)
OPzV2-420	462	475	512	529	536	542	556
Final Voltage	1.80V						

#### Solar & Wind applications parameters settings

Over voltage disconnect:	2.45±0.01V/cell @ 20~25°C
Regulation/equalize voltage:	2.40±0.01V/cell @ 20~25°C
Array reconnection voltage:	2.25±0.005V/cell @ 20~25°C
Float voltage setting:	2.27±0.005V/cell @ 20~25°C
Low voltage alarm voltage:	1.95±0.005V/cell @ 20~25°C
Low voltage disconnect:	1.90±0.005V/cell @ 20~25°C
Load reconnect voltage:	2.09±0.01V/cell @ 20~25°C
Temp. compensate coefficient:	-5mV/cell/°C

## CHARACTERISTICS

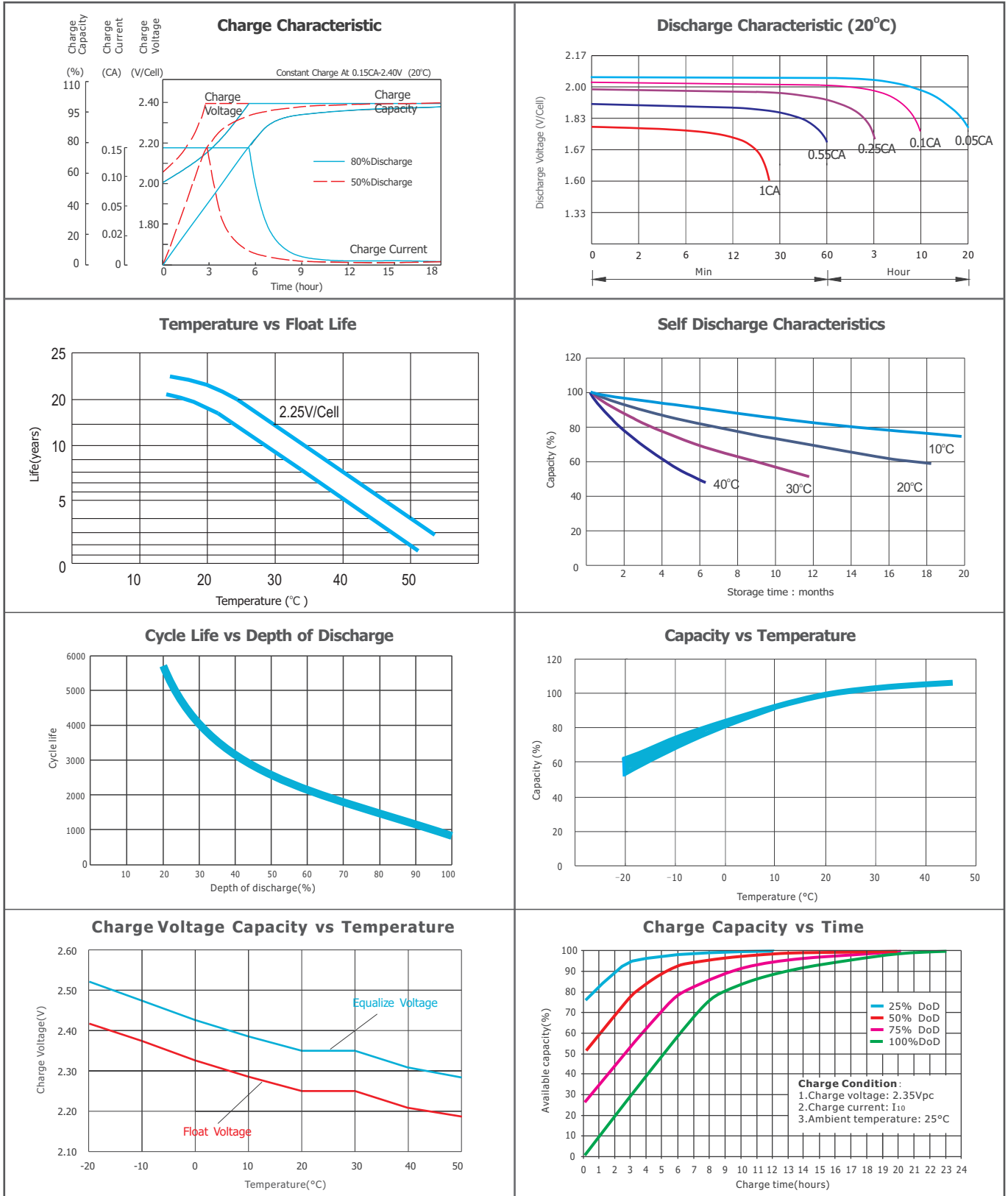

### FINAL VOLTAGE SETTINGS RECOMMENDED ACCORDING TO THE DISCHARGE CURRENT

Discharge Current I (A)	I < 0.05C	0.05C ≤ I < 0.08C	0.08C ≤ I < 0.2C	0.2C ≤ I < 0.6C	0.6C ≤ I < 1.0C	1C ≤ I ≤ 2C
Final of Voltage	≥1.90 Vpc	≥1.85 Vpc	≥1.80 Vpc	≥1.75 Vpc	≥1.7 Vpc	≥1.6 Vpc

### HEADQUARTERS AND SUBSIDIARIES:

BSB Power Company Limited (HQ)  
BSB Power Europe (France)

BSB Power Malaysia Sdn. Bhd  
PT. BSB Indonesia

BSB Power (Thailand) Co., Ltd  
BSB Power Company Pakistan Ltd