

GENERAL SERIES VRLA BATTERY

GB series offers 5 years full maintenance free design life. With compact design and good reliability, this series is highly suited for security and alarm systems, UPS systems, emergency light systems and other small backup applications.

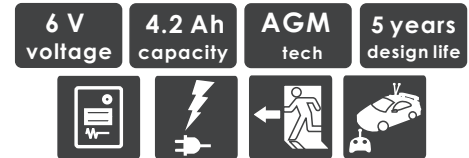

TECHNICAL SPECIFICATIONS

| | |
|---|--|
| Nominal Voltage (V) | 6 (3 cells per unit) |
| Designed Floating Life (20°C) | 5 Years |
| Nominal Capacity (25°C) | 4.2 Ah @ 20HR-rate (to 1.75Vpc) |
| Dimension (mm) | L70mm x W47mm x H107mm |
| Approx. Weight | 0.77 kg (1.70 lbs) |
| Terminal Type | Fasten Tab F1 |
| Internal Resistance | Approx. 0.025 Ohm (fully charged @ 25°C) |
| Max. Charge Current | 1.26 A |
| Max. Discharge Current (5S) | 63 A |
| Short Circuit Current | 480 A |
| Self Discharge | Approx. 3% per month @ 20°C |
| Ambient Temperature | Discharge: -15~55°C Charge: -15~45°C Storage: -15~45°C |
| Float Charge Voltage (20~25°C) | 6.8-6.9V (-3mV/ cell/ °C) |
| Equalize and cycle Use Charge Voltage (20~25°C) | 7.2-7.4V (-5mV/ cell / °C) |
| Container Material | ABS (UL94-V0 optional) |



Complied standards

- IEC 61056
- UL1989
- JIS C8702
- GB/T19639

BATTERY DIMENSIONS

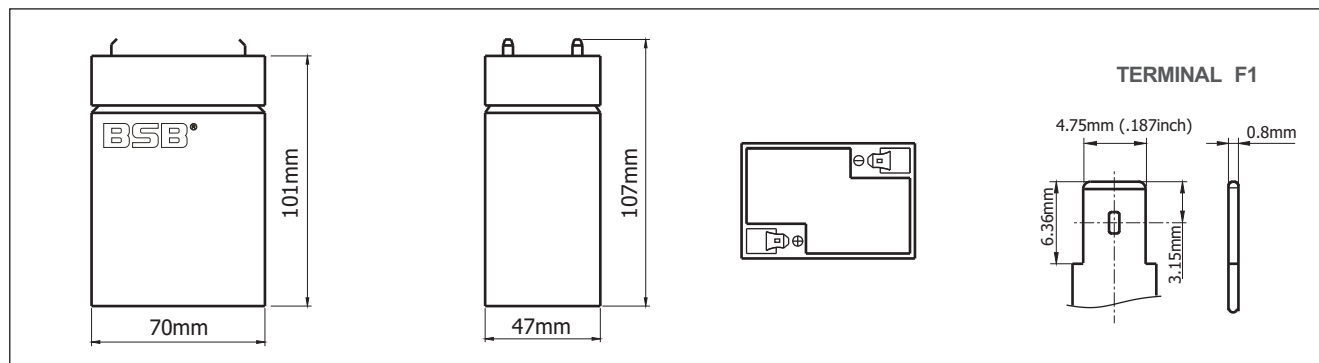

BATTERY DISCHARGE TABLE

| Constant Current Discharge Characteristics: Amps (25°C) | | | | | | | | | | | | |
|---|------|-------|-------|-------|------|------|------|------|------|-------|-------|-------|
| F.V/Time | 5min | 10min | 15min | 30min | 1h | 2h | 3h | 4h | 5h | 8h | 10h | 20h |
| 1.60V | 16.8 | 10.4 | 7.96 | 4.74 | 2.76 | 1.64 | 1.17 | 0.91 | 0.76 | 0.509 | 0.417 | 0.223 |
| 1.67V | 15.6 | 10.1 | 7.69 | 4.63 | 2.73 | 1.62 | 1.16 | 0.90 | 0.75 | 0.503 | 0.411 | 0.219 |
| 1.70V | 14.5 | 9.65 | 7.50 | 4.55 | 2.69 | 1.60 | 1.15 | 0.89 | 0.74 | 0.497 | 0.406 | 0.215 |
| 1.75V | 13.2 | 9.22 | 7.31 | 4.44 | 2.64 | 1.58 | 1.14 | 0.88 | 0.73 | 0.492 | 0.402 | 0.210 |
| 1.80V | 11.9 | 8.71 | 7.13 | 4.37 | 2.59 | 1.56 | 1.12 | 0.87 | 0.72 | 0.487 | 0.397 | 0.205 |
| 1.85V | 10.5 | 8.21 | 6.96 | 4.28 | 2.55 | 1.54 | 1.10 | 0.86 | 0.71 | 0.480 | 0.392 | 0.200 |

| Constant Power Discharge Characteristics: W/cell (25°C) | | | | | | | | | | | | |
|---|------|-------|-------|-------|------|------|------|------|------|-------|-------|-------|
| F.V/Time | 5min | 10min | 15min | 30min | 1h | 2h | 3h | 4h | 5h | 8h | 10h | 20h |
| 1.60V | 29.6 | 18.8 | 14.5 | 8.76 | 5.15 | 3.08 | 2.21 | 1.73 | 1.44 | 0.978 | 0.804 | 0.432 |
| 1.67V | 27.9 | 18.3 | 14.1 | 8.60 | 5.12 | 3.06 | 2.20 | 1.72 | 1.43 | 0.973 | 0.799 | 0.428 |
| 1.70V | 26.2 | 17.7 | 13.9 | 8.52 | 5.08 | 3.05 | 2.19 | 1.71 | 1.42 | 0.969 | 0.795 | 0.423 |
| 1.75V | 24.2 | 17.1 | 13.7 | 8.39 | 5.03 | 3.04 | 2.18 | 1.70 | 1.41 | 0.967 | 0.792 | 0.417 |
| 1.80V | 22.0 | 16.4 | 13.5 | 8.32 | 4.97 | 3.02 | 2.17 | 1.69 | 1.40 | 0.963 | 0.789 | 0.410 |
| 1.85V | 19.7 | 15.6 | 13.3 | 8.23 | 4.94 | 3.00 | 2.16 | 1.68 | 1.39 | 0.957 | 0.783 | 0.402 |

CHARACTERISTICS

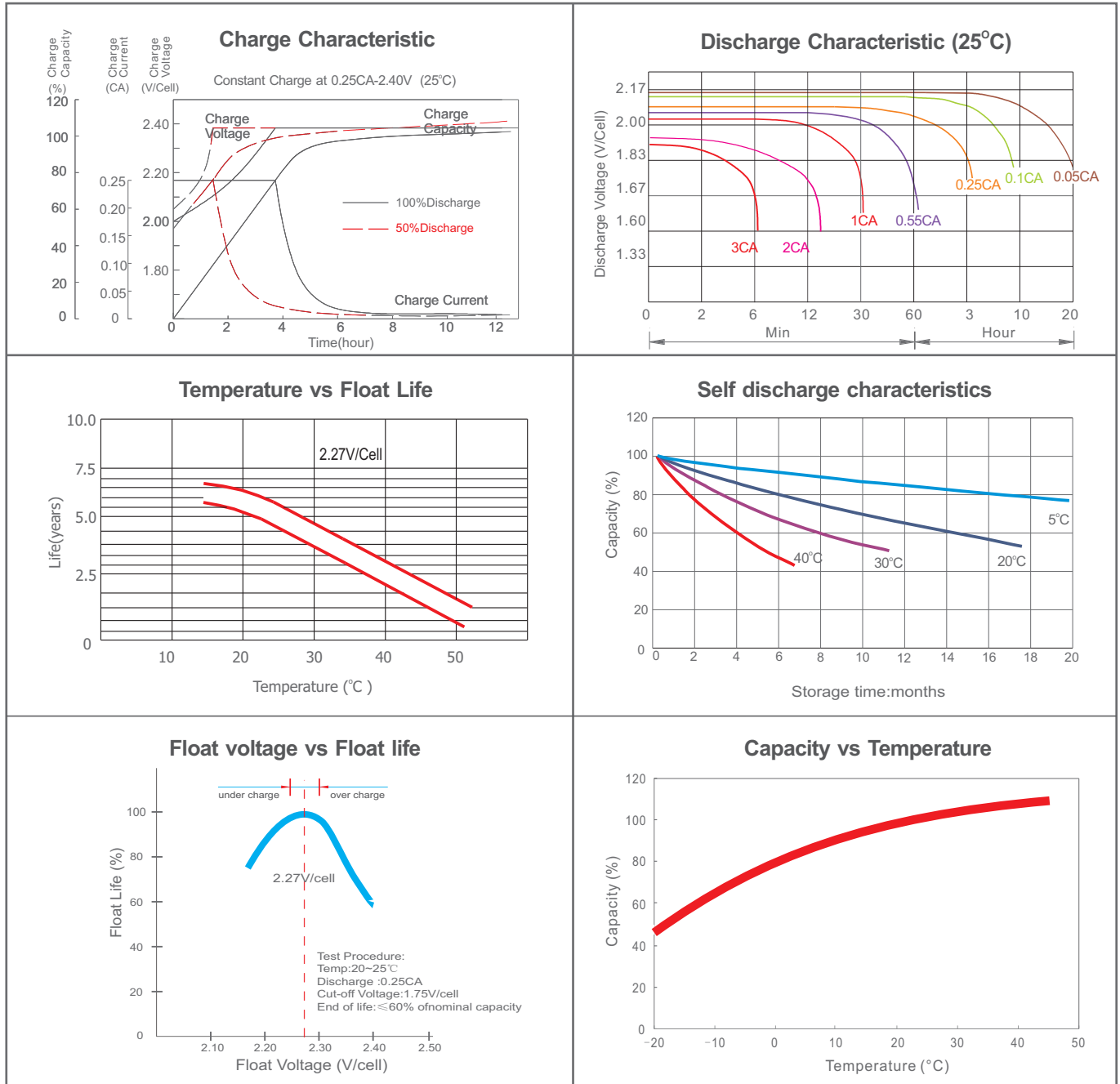

FINAL VOLTAGE SETTINGS RECOMMENDED ACCORDING TO THE DISCHARGE CURRENT

| Discharge Current I (A) | $I \leq 0.08C$ | $0.08C \leq I < 0.2C$ | $0.2C \leq I < 0.6C$ | $0.6C \leq I < 1.0C$ | $I \geq 1.0C$ |
|-------------------------|-------------------|-----------------------|----------------------|----------------------|-------------------|
| Final of Voltage | $\geq 1.85V_{pc}$ | $\geq 1.80V_{pc}$ | $\geq 1.75V_{pc}$ | $\geq 1.70V_{pc}$ | $\geq 1.60V_{pc}$ |

HEADQUARTERS AND SUBSIDIARIES

BSB Power Company Limited (HQ)
 BSB Power Europe (France)
 BSB Power Malaysia Sdn. Bhd
 PT. BSB Indonesia
 BSB Power (Thailand) Co., Ltd
 BSB Power Company Pakistan Ltd

