

FA SERIES VRLA BATTERY

Using up-to-date AGM structures, BSB created the innovation FA range of batteries. The range features 12 years design life and front access connections for fast, easy installation and maintenance. This range battery is highly suited to telecom outdoor applications, renewable energy systems and other harsh environment applications.

12 V voltage	180Ah capacity	AGM tech	12 years design life

TECHNICAL SPECIFICATIONS

Nominal Voltage (V)	12 (6 cells per unit)
Designed Floating Life (20°C)	12 Years
Nominal Capacity (20°C)	180 Ah @ 10HR-rate (to 1.80Vpc)
Dimension (mm)	L546mm x W125mm x H315mm
Approx. Weight	53.5 kg (118 lbs)
Terminal Type	Female Copper Insert M8 (torque:10~12N.m)
Internal Resistance	Approx. 0.004 Ohm (fully charged @ 20°C)
Max. Charge Current	45A
Max. Discharge Current (5S)	1080 A
Short Circuit Current	3000 A
Self Discharge	Approx. 3% per month @ 20°C
Ambient Temperature	Discharge: -15~60°C Charge: -15~60°C Storage: -15~45°C
Float Charge Voltage (20~25°C)	13.5-13.7V (-3mV/ cell/ °C)
Equalize and cycle Use Charge Voltage (20~25°C)	14.1-14.4V (-5mV/ cell / °C)
Container Material	ABS (UL94-V0 optional)



Complied standards

- IEC 60896-21/22
- UL1989
- JIS C8704
- GB/T19639

BATTERY DIMENSIONS

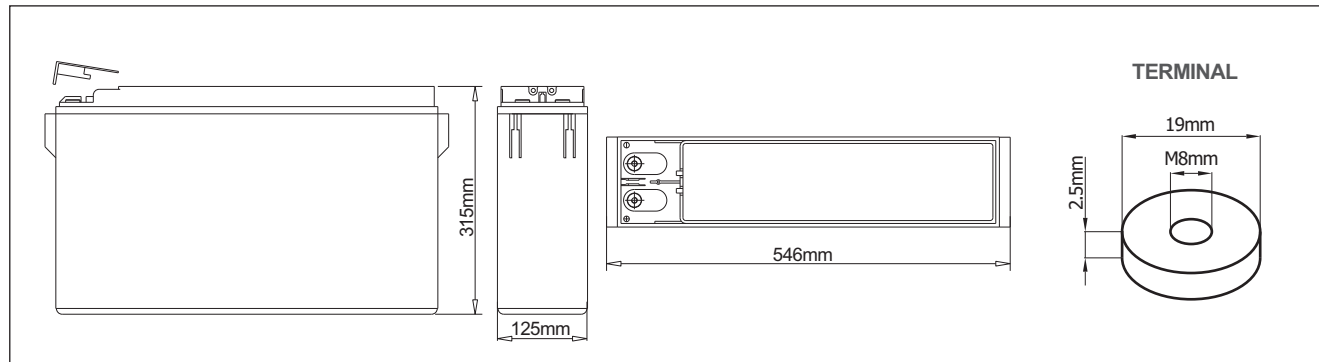

BATTERY DISCHARGE TABLE

Constant Current Discharge Characteristics: Amps (20°C)												
F.V/Time	5m in	10m in	15m in	30m in	1h	2h	3h	4h	5h	8h	10h	20h
1.60V	462	324	278	173	119	68.3	49.4	39.7	32.7	23.0	19.1	9.90
1.67V	412	298	262	167	116	67.2	48.8	38.9	32.3	22.7	18.8	9.81
1.70V	368	271	247	161	114	66.3	48.3	38.5	32.0	22.5	18.6	9.68
1.75V	320	252	230	155	112	65.1	47.5	38.1	31.5	22.1	18.4	9.59
1.80V	283	229	214	149	108	63.2	46.4	37.2	31.1	21.6	18.0	9.54
1.85V	242	206	195	140	105	60.8	44.4	36.0	30.1	20.8	17.4	9.00

Constant Power Discharge Characteristics: W/cell (20°C)												
F.V/Time	5m in	10m in	15m in	30m in	1h	2h	3h	4h	5h	8h	10h	20h
1.60V	813	582	507	319	221	128	93.3	75.3	62.2	44.2	36.9	19.7
1.67V	735	542	481	311	218	127	92.8	74.2	60.8	43.9	36.6	19.5
1.70V	664	497	459	301	216	126	92.3	74.0	61.8	43.6	36.4	19.3
1.75V	584	467	431	293	212	125	91.7	73.8	61.3	43.3	36.2	19.1
1.80V	524	430	405	283	207	122	90.4	72.7	61.1	42.8	35.8	18.9
1.85V	456	392	373	270	203	119	87.2	71.1	59.5	41.5	34.7	18.1

CHARACTERISTICS

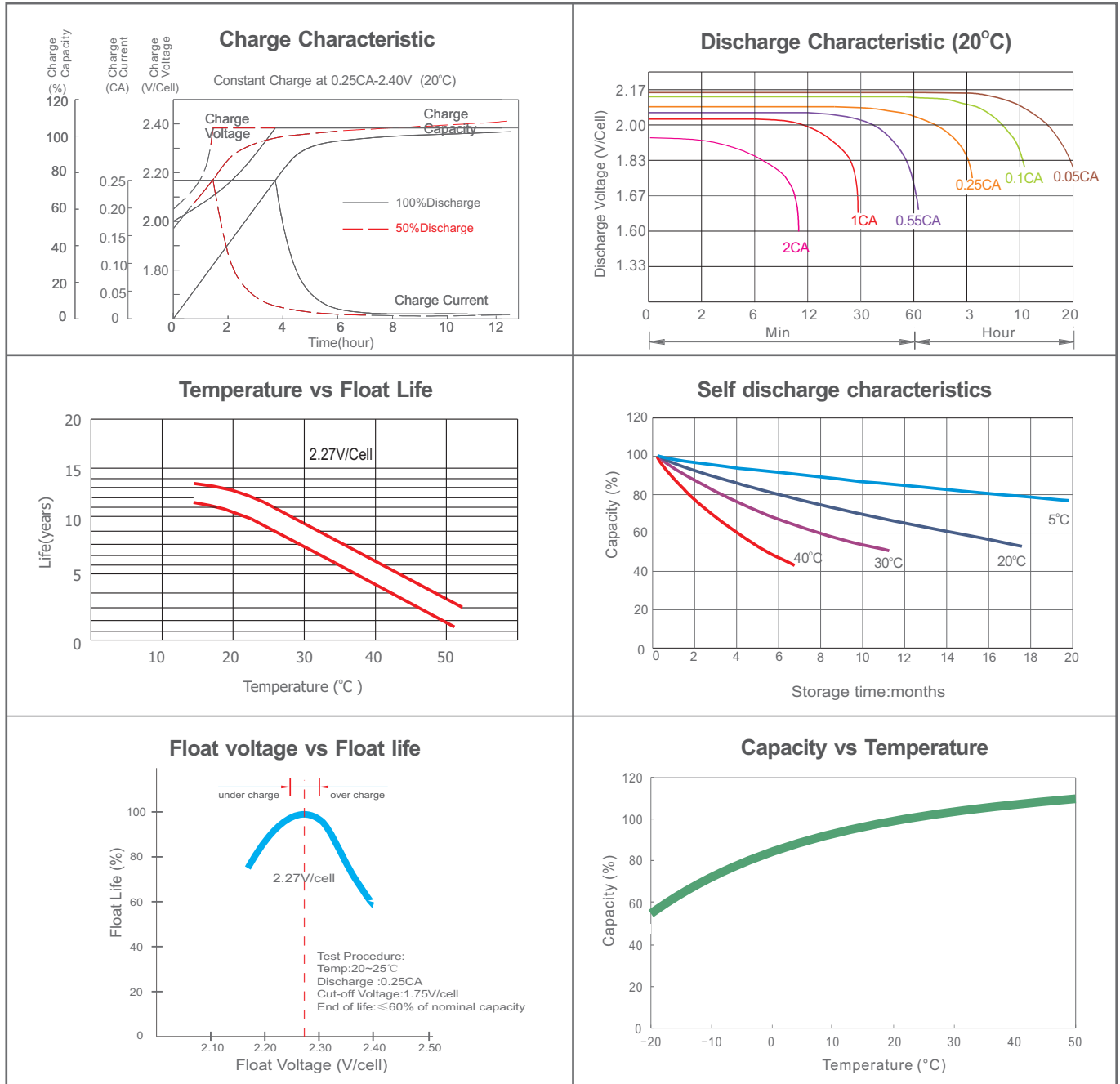

FINAL VOLTAGE SETTINGS RECOMMENDED ACCORDING TO THE DISCHARGE CURRENT

Discharge Current I (A)	$I \leq 0.08C$	$0.08C \leq I < 0.2C$	$0.2C \leq I < 0.6C$	$0.6C \leq I < 1.0C$	$I \geq 1.0C$
Final of Voltage	$\geq 1.85V_{pc}$	$\geq 1.80V_{pc}$	$\geq 1.75V_{pc}$	$\geq 1.70V_{pc}$	$\geq 1.60V_{pc}$

HEADQUARTERS AND SUBSIDIARIES

BSB Power Company Limited (HQ)
 BSB Power Europe (France)
 BSB Power Malaysia Sdn. Bhd
 PT. BSB Indonesia
 BSB Power (Thailand) Co., Ltd
 BSB Power Company Pakistan Ltd

