

## FA SERIES VRLA BATTERY

Using up-to-date AGM structures, BSB created the innovation FA range of batteries. The range features 12 years design life and front access connections for fast, easy installation and maintenance. This range battery is highly suited to telecom outdoor applications, renewable energy systems and other harsh environment applications.



### TECHNICAL SPECIFICATIONS

Nominal Voltage (V)	12 (6 cells per unit)
Designed Floating Life (20°C)	12 Years
Nominal Capacity (20°C)	155 Ah @ 10HR-rate (to 1.80Vpc)
Dimension (mm)	L550mm x W110mm x H285mm
Approx. Weight	48.0 kg (106 lbs)
Terminal Type	Female Copper Insert M8 (torque:10~12N.m)
Internal Resistance	Approx. 0.0048 Ohm (fully charged @ 20°C)
Max. Charge Current	38.75A
Max. Discharge Current (5S)	900 A
Short Circuit Current	2500 A
Self Discharge	Approx. 3% per month @ 20°C
Ambient Temperature	Discharge: -15~60°C Charge: -15~60°C Storage: -15~45°C
Float Charge Voltage (20~25°C)	13.5-13.7V (-3mV/ cell/ °C)
Equalize and cycle Use Charge Voltage (20~25°C)	14.1-14.4V (-5mV/ cell / °C)
Container Material	ABS (UL94-V0 optional)



#### Complied standards

- IEC 60896-21/22
- UL1989
- JIS C8704
- GB/T19639

### BATTERY DIMENSIONS

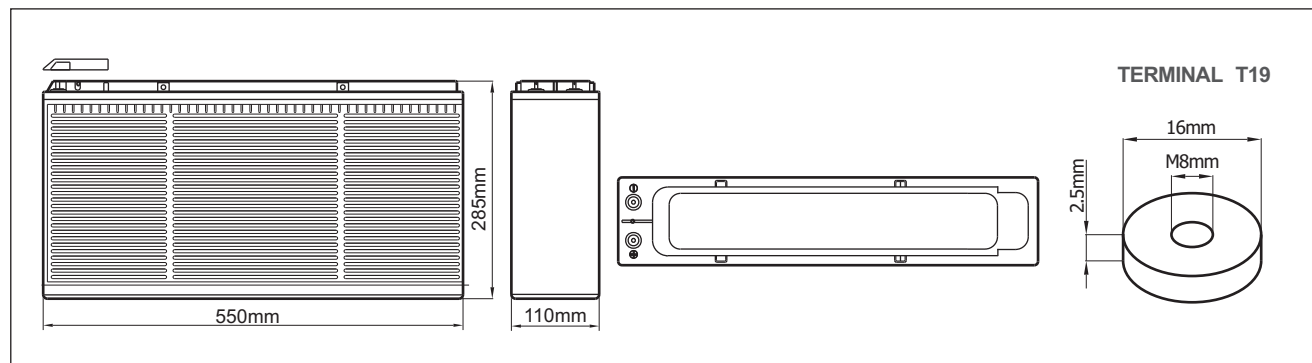

### BATTERY DISCHARGE TABLE

Constant Current Discharge Characteristics: Amps (20°C)												
F.V/Time	5 m in	10 m in	15 m in	30 m in	1 h	2 h	3 h	4 h	5 h	8 h	10 h	20 h
1.60V	419	293	252	157	102	58.8	42.6	34.2	28.1	19.8	16.4	8.53
1.67V	373	270	237	152	100	57.8	42.1	33.5	27.8	19.5	16.2	8.45
1.70V	333	246	224	146	98.4	57.1	41.6	33.1	27.6	19.4	16.0	8.33
1.75V	290	228	208	141	96.1	56.1	40.9	32.8	27.1	19.0	15.8	8.25
1.80V	256	207	194	135	93.0	54.4	40.0	32.0	26.8	18.6	15.5	8.20
1.85V	219	187	177	127	90.3	52.3	38.2	31.0	25.9	17.9	15.0	7.75

Constant Power Discharge Characteristics: W/cell (20°C)												
F.V/Time	5 m in	10 m in	15 m in	30 m in	1 h	2 h	3 h	4 h	5 h	8 h	10 h	20 h
1.60V	737	527	460	289	191	111	80.4	64.8	53.6	38.1	31.7	16.9
1.67V	666	491	436	282	187	109	79.9	63.9	52.3	37.8	31.5	16.8
1.70V	602	451	416	273	186	109	79.5	63.7	53.2	37.6	31.4	16.6
1.75V	530	424	390	266	183	101	78.9	63.5	52.8	37.3	31.2	16.5
1.80V	475	389	367	256	179	105	77.9	62.6	52.6	36.8	30.8	16.4
1.85V	413	355	338	245	175	102	75.1	61.2	51.2	35.7	29.9	15.6

## CHARACTERISTICS

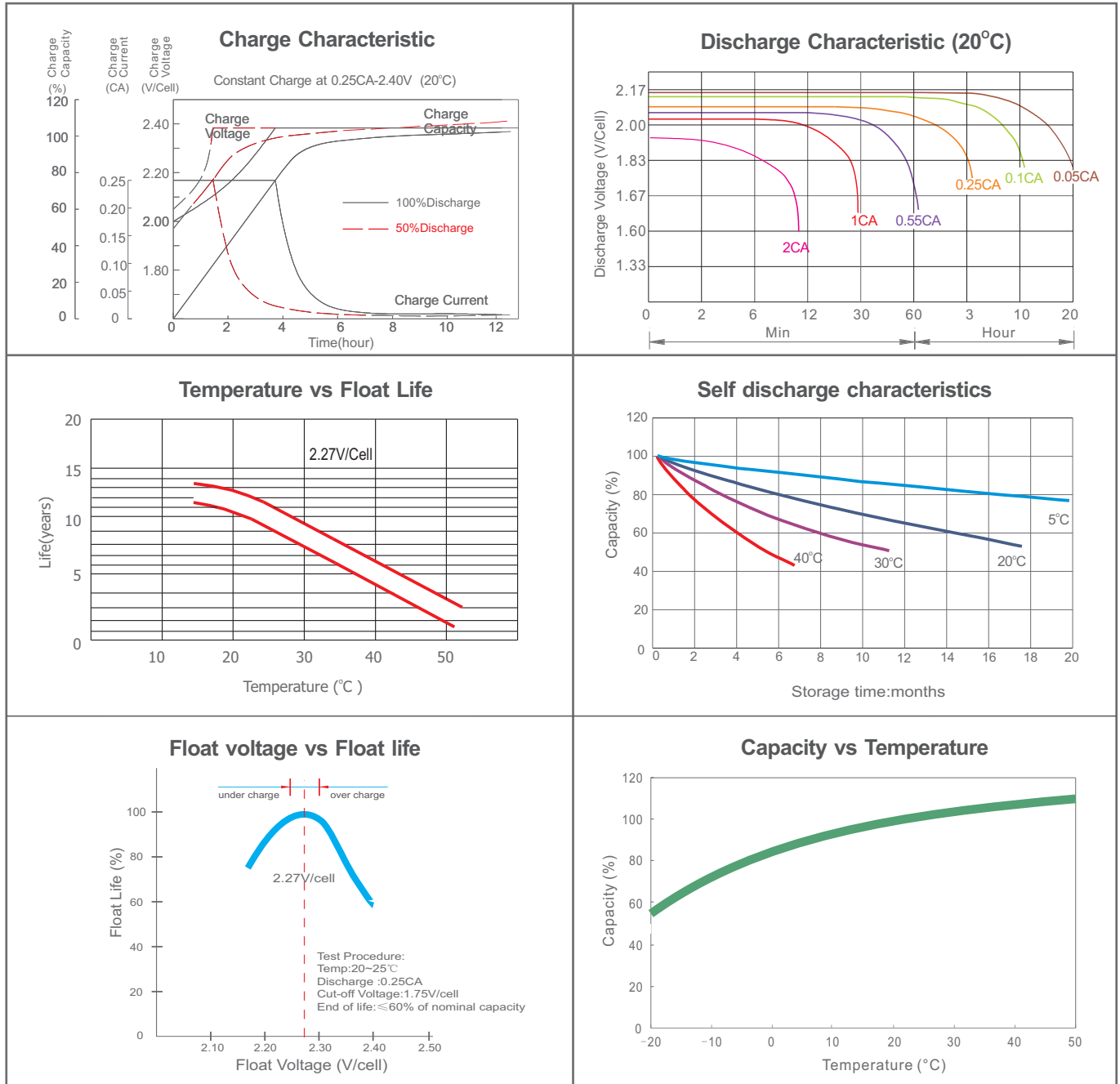

## FINAL VOLTAGE SETTINGS RECOMMENDED ACCORDING TO THE DISCHARGE CURRENT

Discharge Current I (A)	$I \leq 0.08C$	$0.08C \leq I < 0.2C$	$0.2C \leq I < 0.6C$	$0.6C \leq I < 1.0C$	$I \geq 1.0C$
Final of Voltage	$\geq 1.85V_{pc}$	$\geq 1.80V_{pc}$	$\geq 1.75V_{pc}$	$\geq 1.70V_{pc}$	$\geq 1.60V_{pc}$

## HEADQUARTERS AND SUBSIDIARIES

BSB Power Company Limited (HQ)  
 BSB Power Europe (France)  
 BSB Power Malaysia Sdn. Bhd  
 PT. BSB Indonesia  
 BSB Power (Thailand) Co., Ltd  
 BSB Power Company Pakistan Ltd

