

FA SERIES VRLA BATTERY

Using up-to-date AGM structures, BSB created the innovation FA range of batteries. The range features 12 years design life and front access connections for fast, easy installation and maintenance. This range battery is highly suited to telecom outdoor applications, renewable energy systems and other harsh environment applications.



TECHNICAL SPECIFICATIONS

Nominal Voltage (V)	12 (6 cells per unit)
Designed Floating Life (20°C)	12 Years
Nominal Capacity (20°C)	100 Ah @ 10HR-rate (to 1.80Vpc)
Dimension (mm)	L395mm x W110mm x H285mm
Approx. Weight	31.5 kg (69.5 lbs)
Terminal Type	Female Copper Insert M8 (torque:10~12N.m)
Internal Resistance	Approx. 0.0055 Ohm (fully charged @ 20°C)
Max. Charge Current	25A
Max. Discharge Current (5S)	800 A
Short Circuit Current	2000 A
Self Discharge	Approx. 3% per month @ 20°C
Ambient Temperature	Discharge: -15~60°C Charge: -15~60°C Storage: -15~45°C
Float Charge Voltage (20~25°C)	13.5-13.7V (-3mV/ cell/ °C)
Equalize and cycle Use Charge Voltage (20~25°C)	14.1-14.4V (-5mV/ cell / °C)
Container Material	ABS (UL94-V0 optional)



Complied standards

- IEC 60896-21/22
- UL1989
- JIS C8704
- GB/T19639

BATTERY DIMENSIONS

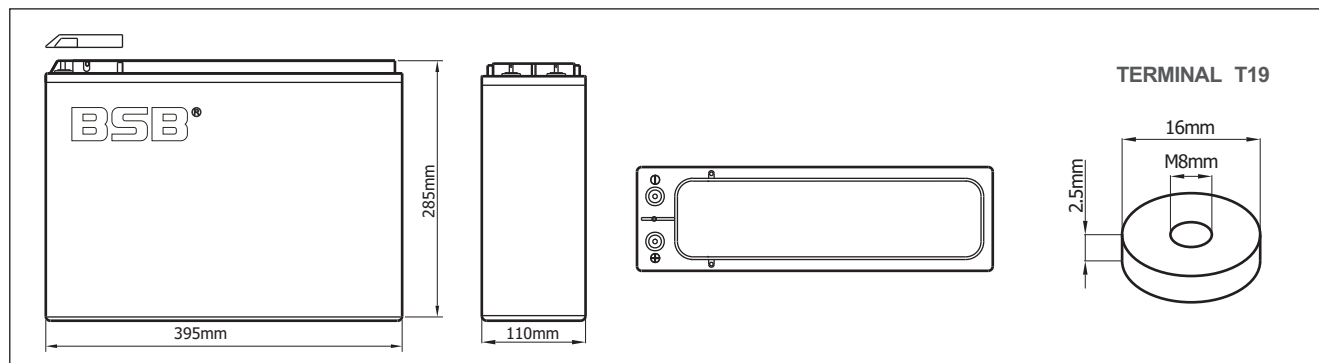

BATTERY DISCHARGE TABLE

Constant Current Discharge Characteristics: Amps (20°C)												
F.V/Time	5 m in	10 m in	15 m in	30 m in	1 h	2 h	3 h	4 h	5 h	8 h	10 h	20 h
1.60V	270	189	163	101	66.0	38.0	27.5	22.1	18.2	12.8	10.6	5.50
1.67V	241	174	153	97.8	64.5	37.3	27.1	21.6	18.0	12.6	10.5	5.45
1.70V	215	158	145	94.1	63.5	36.8	26.8	21.4	17.8	12.5	10.3	5.38
1.75V	187	147	134	90.8	62.0	36.2	26.4	21.1	17.5	12.3	10.2	5.33
1.80V	165	134	125	86.8	60.0	35.1	25.8	20.6	17.3	12.0	10.0	5.30
1.85V	142	121	114	81.9	58.3	33.8	24.7	20.0	16.7	11.6	9.65	5.00

Constant Power Discharge Characteristics: W/cell (20°C)												
F.V/Time	5 m in	10 m in	15 m in	30 m in	1 h	2 h	3 h	4 h	5 h	8 h	10 h	20 h
1.60V	475	340	297	187	123	71.3	51.8	41.8	34.6	24.6	20.5	10.9
1.67V	430	317	281	182	121	70.5	51.6	41.2	33.8	24.4	20.3	10.8
1.70V	388	291	268	176	120	70.1	51.3	41.1	34.4	24.2	20.2	10.7
1.75V	342	273	252	172	118	69.5	50.9	41.0	34.1	24.1	20.1	10.6
1.80V	306	251	237	165	115	68.0	50.2	40.4	33.9	23.8	19.9	10.5
1.85V	267	229	218	158	113	66.0	48.4	39.5	33.0	23.0	19.3	10.1

CHARACTERISTICS

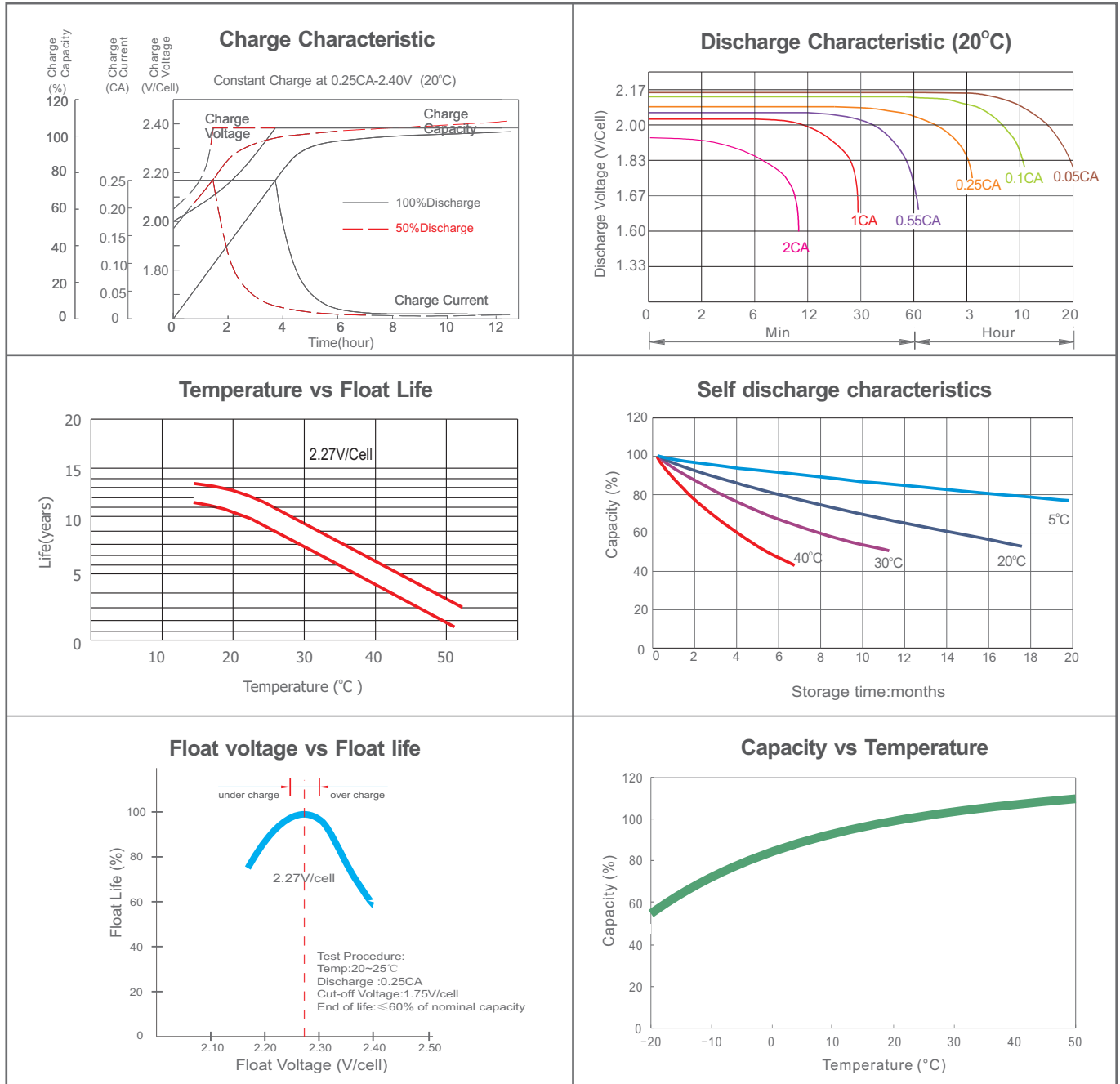

FINAL VOLTAGE SETTINGS RECOMMENDED ACCORDING TO THE DISCHARGE CURRENT

Discharge Current I (A)	$I \leq 0.08C$	$0.08C \leq I < 0.2C$	$0.2C \leq I < 0.6C$	$0.6C \leq I < 1.0C$	$I \geq 1.0C$
Final of Voltage	$\geq 1.85V_{pc}$	$\geq 1.80V_{pc}$	$\geq 1.75V_{pc}$	$\geq 1.70V_{pc}$	$\geq 1.60V_{pc}$

HEADQUARTERS AND SUBSIDIARIES

BSB Power Company Limited (HQ)
 BSB Power Europe (France)
 BSB Power Malaysia Sdn. Bhd
 PT. BSB Indonesia
 BSB Power (Thailand) Co., Ltd
 BSB Power Company Pakistan Ltd

