

DURATION SERIES VRLA BATTERY

By combining up-to-date DCP-II formula in the positive plates and enhanced electrolyte for VRLA, BSB created an innovative range of DC batteries. This range features deep cycling use with higher cyclic life when compared with the standard Duration range. This series is highly suited to cyclic applications such as outdoor applications, small RE systems and electric vehicles.

6 V voltage **180Ah** capacity **AGM** tech **Enhanced deep cycling**



TECHNICAL SPECIFICATIONS

Nominal Voltage (V)	6 (3 cells per unit)
Designed Floating Life (20°C)	12 Years
Nominal Capacity (20°C)	180 Ah @ 10HR-rate (to 1.80Vpc)
Dimension (mm)	L307mm x W169mm x H225mm
Approx. Weight	25.0 kg (55.1 lbs)
Terminal Type	Female Copper Insert M8 (torque:10~12N.m)
Internal Resistance	Approx. 0.0032 Ohm (fully charged @ 20°C)
Max. Charge Current	37.5A
Max. Discharge Current (5S)	1000 A
Short Circuit Current	1850 A
Self Discharge	Approx. 3% per month @ 20°C
Ambient Temperature	Discharge: -20~60°C Charge: -20~60°C Storage: -20~45°C
Float Charge Voltage (20~25°C)	6.8-6.9V (-3mV/ cell / °C)
Equalize and cycle Use Charge Voltage (20~25°C)	7.2-7.4V (-5mV/ cell / °C)
Container Material	ABS (UL94-V0 optional)



Complied standards

- IEC 60896-21/22
- UL1989
- JIS C8704
- GB/T19638

BATTERY DIMENSIONS

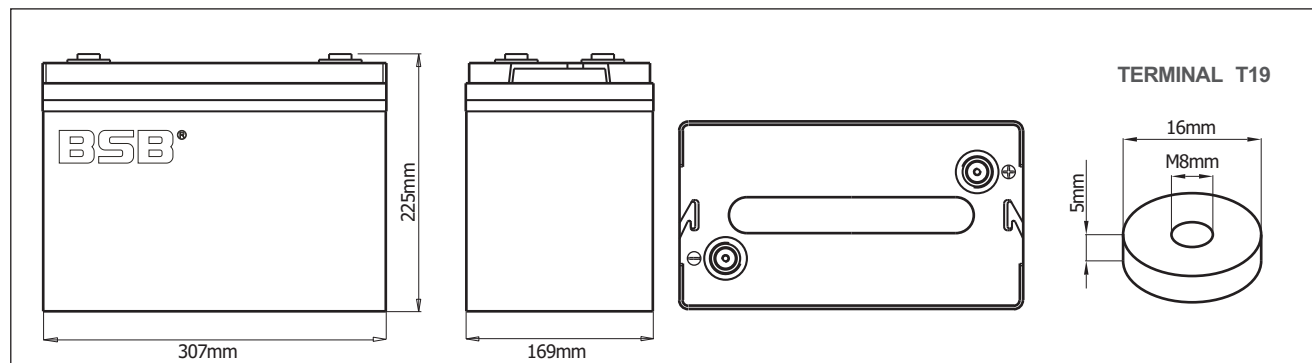

BATTERY DISCHARGE TABLE

Constant Current Discharge Characteristics: Amps (25°C)											
F.V/Time	10 m in	15 m in	30 m in	1 h	2 h	3 h	4 h	5 h	8 h	10 h	20 h
1.60V	383	316	195	119	69.9	50.5	40.7	33.9	23.1	19.1	10.3
1.67V	352	298	186	116	68.7	49.9	40.1	33.4	22.8	18.8	10.0
1.70V	320	281	179	113	67.8	49.3	39.7	33.1	22.5	18.6	9.82
1.75V	298	261	173	111	66.7	48.5	39.3	32.7	22.2	18.4	9.63
1.80V	271	244	165	107	65.2	47.6	38.4	31.9	21.7	18.0	9.45
1.85V	244	222	156	103	62.7	46.0	37.3	31.2	21.2	17.5	9.23

Constant Power Discharge Characteristics: W/cell (25°C)											
F.V/Time	10 m in	15 m in	30 m in	1 h	2 h	3 h	4 h	5 h	8 h	10 h	20 h
1.60V	687	576	360	222	131	95.3	77.1	64.5	44.5	36.9	19.9
1.67V	640	547	345	218	130	94.8	76.5	64.1	44.1	36.6	19.6
1.70V	588	521	335	214	129	94.3	76.3	64.0	43.9	36.4	19.3
1.75V	552	489	326	211	128	93.7	76.1	63.7	43.7	36.2	19.1
1.80V	508	461	315	206	126	92.7	75.0	62.7	43.0	35.8	18.9
1.85V	463	424	300	199	123	90.4	73.5	61.7	42.3	35.0	18.5

CHARACTERISTICS

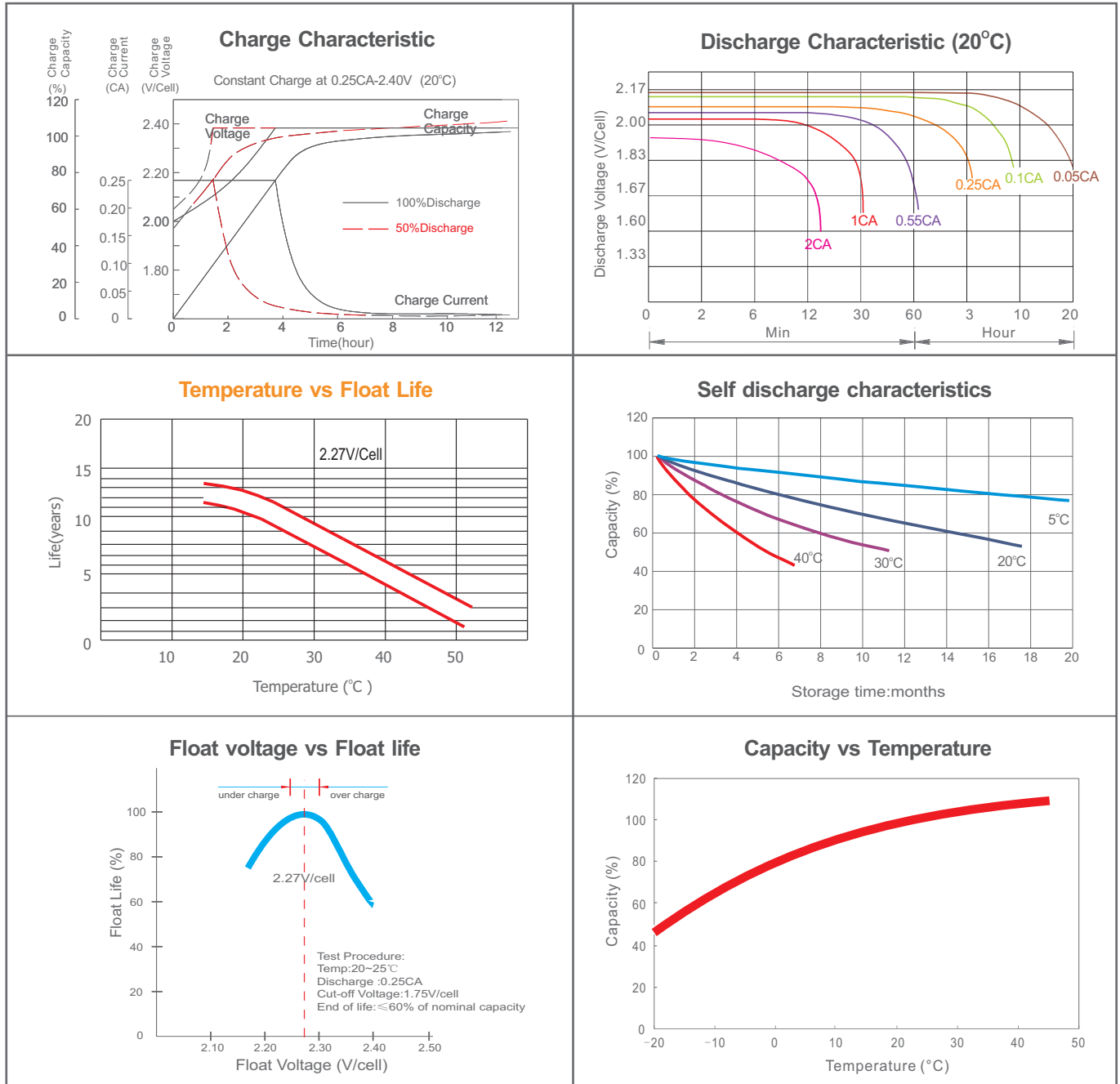

FINAL VOLTAGE SETTINGS RECOMMENDED ACCORDING TO THE DISCHARGE CURRENT

Discharge Current I (A)	$I \leq 0.08C$	$0.08C \leq I < 0.2C$	$0.2C \leq I < 0.6C$	$0.6C \leq I < 1.0C$	$I \geq 1.0C$
Final of Voltage	$\geq 1.85V_{pc}$	$\geq 1.80V_{pc}$	$\geq 1.75V_{pc}$	$\geq 1.70V_{pc}$	$\geq 1.60V_{pc}$

HEADQUARTERS AND SUBSIDIARIES

BSB Power Company Limited (HQ)
 BSB Power Europe (France)
 BSB Power Malaysia Sdn. Bhd
 PT. BSB Indonesia
 BSB Power (Thailand) Co., Ltd
 BSB Power Company Pakistan Ltd

