

## DURATION SERIES VRLA BATTERY

By combining up-to-date DCP-II formula in the positive plates and enhanced electrolyte for VRLA, BSB created an innovative range of DC batteries. This range features deep cycling use with higher cyclic life when compared with the standard Duration range. This series is highly suited to cyclic applications such as outdoor applications, small RE systems and electric vehicles.

**6 V** voltage    **100Ah** capacity    **AGM** tech    **Enhanced deep cycling**



### TECHNICAL SPECIFICATIONS

Nominal Voltage (V)	6 (3 cells per unit)
Designed Floating Life (20°C)	12 Years
Nominal Capacity (20°C)	100 Ah @ 10HR-rate (to 1.80Vpc)
Dimension (mm)	L194mm x W170mm x H210mm
Approx. Weight	16.5 kg (36.4 lbs)
Terminal Type	Female Copper Insert M6 (torque:6~7N.m)
Internal Resistance	Approx. 0.0035 Ohm (fully charged @ 20°C)
Max. Charge Current	25A
Max. Discharge Current (5S)	800 A
Short Circuit Current	1700 A
Self Discharge	Approx. 3% per month @ 20°C
Ambient Temperature	Discharge: -20~60°C Charge: -20~60°C Storage: -20~45°C
Float Charge Voltage (20~25°C)	6.8-6.9V (-3mV/ cell/ °C)
Equalize and cycle Use Charge Voltage (20~25°C)	7.2-7.4V (-5mV/ cell / °C)
Container Material	ABS (UL94-V0 optional)



#### Complied standards

- IEC 60896-21/22
- UL1989
- JIS C8704
- GB/T19638

### BATTERY DIMENSIONS

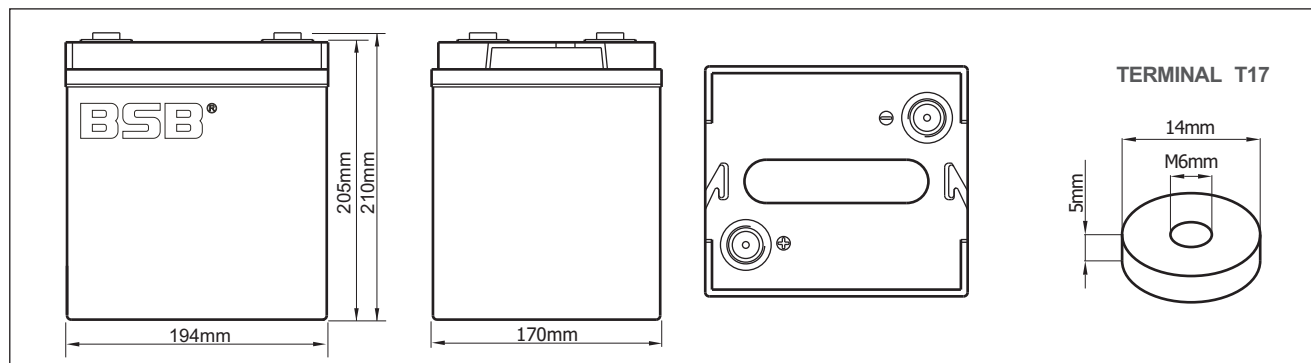

### BATTERY DISCHARGE TABLE

Constant Current Discharge Characteristics: Amps (25°C)											
F.V/Time	10 m in	15 m in	30 m in	1 h	2 h	3 h	4 h	5 h	8 h	10 h	20 h
1.60V	213	175	108	66.2	38.9	28.1	22.6	18.8	12.9	10.6	5.71
1.67V	196	165	103	64.5	38.2	27.7	22.3	18.6	12.7	10.5	5.58
1.70V	178	156	99.5	63.0	37.7	27.4	22.1	18.4	12.5	10.3	5.45
1.75V	165	145	96.0	61.7	37.0	27.0	21.8	18.2	12.4	10.2	5.35
1.80V	150	135	91.8	59.7	36.2	26.4	21.3	17.7	12.1	10.0	5.25
1.85V	135	123	86.6	57.1	34.8	25.6	20.7	17.3	11.8	9.74	5.13

Constant Power Discharge Characteristics: W/cell (25°C)											
F.V/Time	10 m in	15 m in	30 m in	1 h	2 h	3 h	4 h	5 h	8 h	10 h	20 h
1.60V	382	320	200	123	73.0	53.0	42.8	35.8	24.7	20.5	11.1
1.67V	356	304	192	121	72.1	52.7	42.5	35.6	24.5	20.3	10.9
1.70V	327	290	186	119	71.8	52.4	42.4	35.5	24.4	20.2	10.7
1.75V	307	272	181	117	71.1	52.0	42.3	35.4	24.3	20.1	10.6
1.80V	282	256	175	115	70.2	51.5	41.7	34.8	23.9	19.9	10.5
1.85V	257	236	167	111	68.1	50.2	40.8	34.3	23.5	19.5	10.3

## CHARACTERISTICS

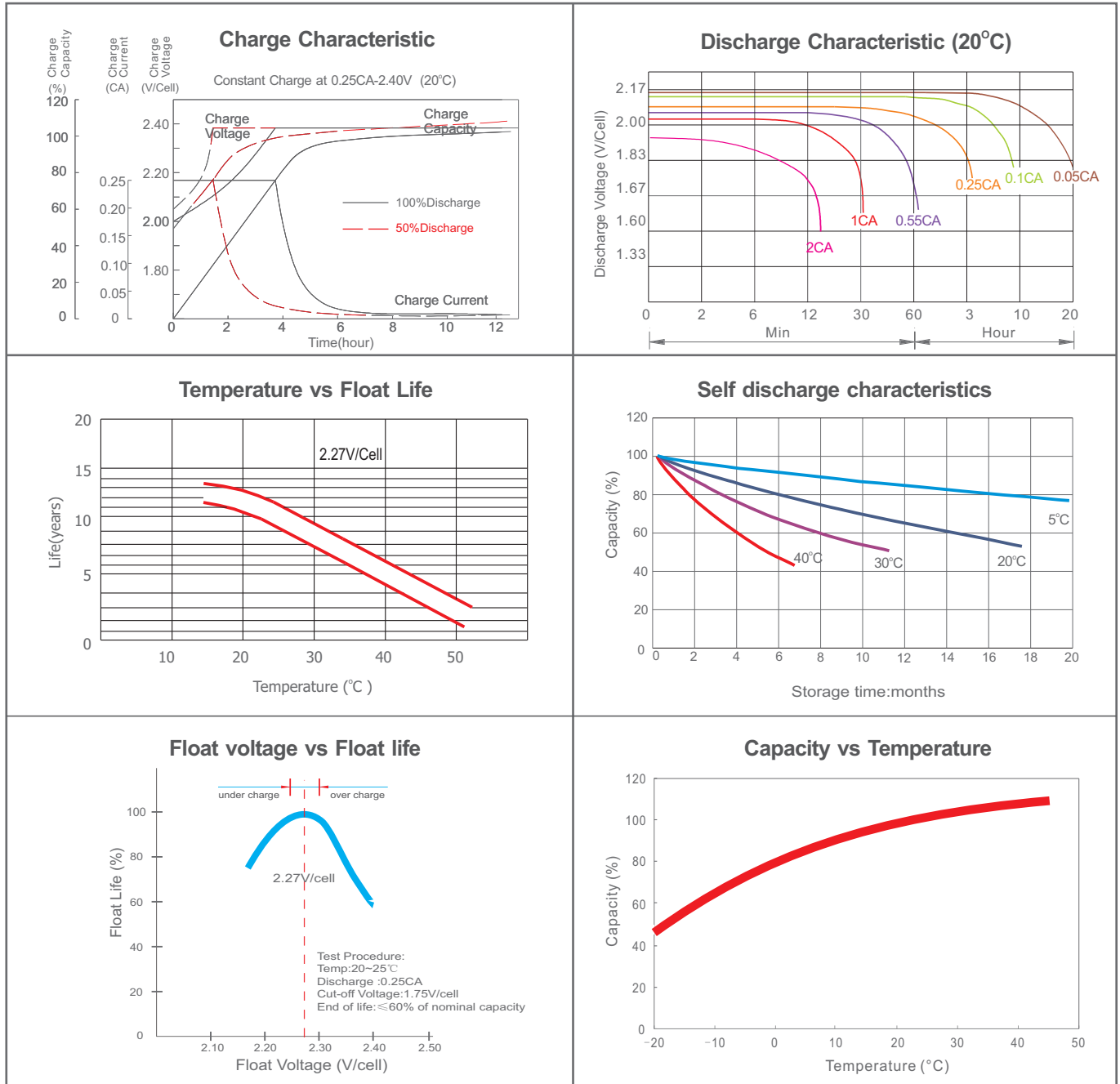

## FINAL VOLTAGE SETTINGS RECOMMENDED ACCORDING TO THE DISCHARGE CURRENT

Discharge Current I (A)	$I \leq 0.08C$	$0.08C \leq I < 0.2C$	$0.2C \leq I < 0.6C$	$0.6C \leq I < 1.0C$	$I \geq 1.0C$
Final of Voltage	$\geq 1.85V_{pc}$	$\geq 1.80V_{pc}$	$\geq 1.75V_{pc}$	$\geq 1.70V_{pc}$	$\geq 1.60V_{pc}$

## HEADQUARTERS AND SUBSIDIARIES

BSB Power Company Limited (HQ)  
 BSB Power Europe (France)  
 BSB Power Malaysia Sdn. Bhd  
 PT. BSB Indonesia  
 BSB Power (Thailand) Co., Ltd  
 BSB Power Company Pakistan Ltd

