

## DURATION SERIES VRLA BATTERY

By combining up-to-date DCP-II formula in the positive plates and enhanced electrolyte for VRLA, BSB created an innovative range of DC batteries. This range features deep cycling use with higher cyclic life when compared with the standard Duration range. This series is highly suited to cyclic applications such as outdoor applications, small RE systems and electric vehicles.

**12 V** voltage    **65Ah** capacity    **AGM** tech    **Enhanced deep cycling**



### TECHNICAL SPECIFICATIONS

Nominal Voltage (V)	12 (6 cells per unit)
Designed Floating Life (20°C)	12 Years
Nominal Capacity (20°C)	65 Ah @ 10HR-rate (to 1.80Vpc)
Dimension (mm)	L350mm x W166mm x H179mm
Approx. Weight	21.2 kg (46.7 lbs)
Terminal Type	Female Copper Insert M6 (torque:6~7N.m)
Internal Resistance	Approx. 0.006 Ohm (fully charged @ 20°C)
Max. Charge Current	16A
Max. Discharge Current (5S)	650 A
Short Circuit Current	2000 A
Self Discharge	Approx. 3% per month @ 20°C
Ambient Temperature	Discharge: -20~60°C Charge: -20~60°C Storage: -20~45°C
Float Charge Voltage (20~25°C)	13.6-13.8V (-3mV/ cell/ °C)
Equalize and cycle Use Charge Voltage (20~25°C)	14.4-14.8V (-5mV/ cell / °C)
Container Material	ABS (UL94-V0 optional)



#### Complied standards

- IEC 60896-21/22
- UL1989
- JIS C8704
- GB/T19638

### BATTERY DIMENSIONS

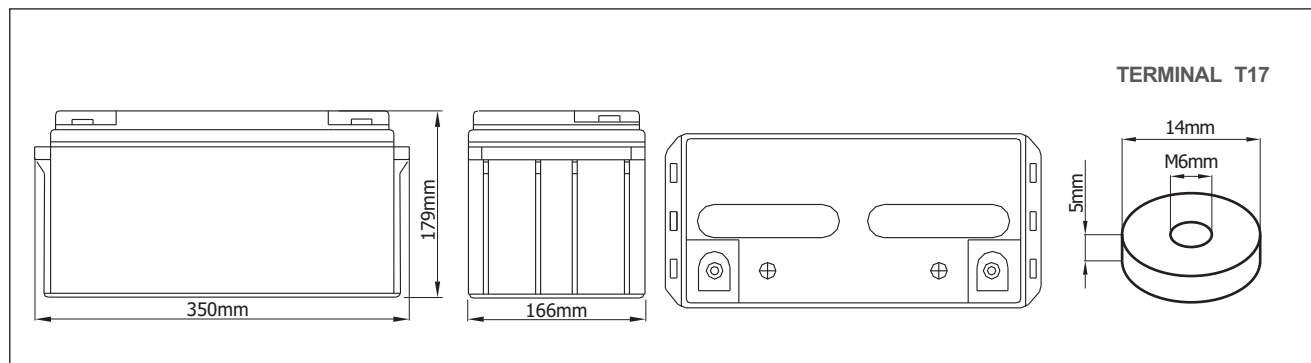

### BATTERY DISCHARGE TABLE

Constant Current Discharge Characteristics: Amps (25°C)											
F.V/Time	10m in	15m in	30m in	1h	2h	3h	4h	5h	8h	10h	20h
1.60V	138	114	70.3	43.0	25.3	18.2	14.7	12.2	8.35	6.89	3.71
1.67V	127	107	67.1	41.9	24.8	18.0	14.5	12.1	8.24	6.81	3.63
1.70V	116	102	64.6	41.0	24.5	17.8	14.3	12.0	8.14	6.72	3.54
1.75V	107	94.3	62.4	40.1	24.1	17.5	14.2	11.8	8.03	6.63	3.48
1.80V	97.7	87.9	59.7	38.8	23.6	17.2	13.9	11.5	7.84	6.50	3.41
1.85V	88.0	80.1	56.3	37.1	22.6	16.6	13.5	11.3	7.67	6.33	3.33

Constant Power Discharge Characteristics: W/cell (25°C)											
F.V/Time	10m in	15m in	30m in	1h	2h	3h	4h	5h	8h	10h	20h
1.60V	248	208	130	80.2	47.4	34.4	27.8	23.3	16.1	13.3	7.20
1.67V	231	197	125	78.6	46.9	34.2	27.7	23.2	16.0	13.2	7.09
1.70V	212	188	121	77.3	46.6	34.1	27.6	23.1	15.9	13.1	6.99
1.75V	199	177	118	76.4	46.2	33.8	27.5	23.0	15.8	13.0	6.89
1.80V	183	166	114	74.5	45.6	33.5	27.1	22.6	15.5	12.9	6.81
1.85V	167	153	108	72.0	44.3	32.7	26.5	22.3	15.3	12.7	6.70

## CHARACTERISTICS

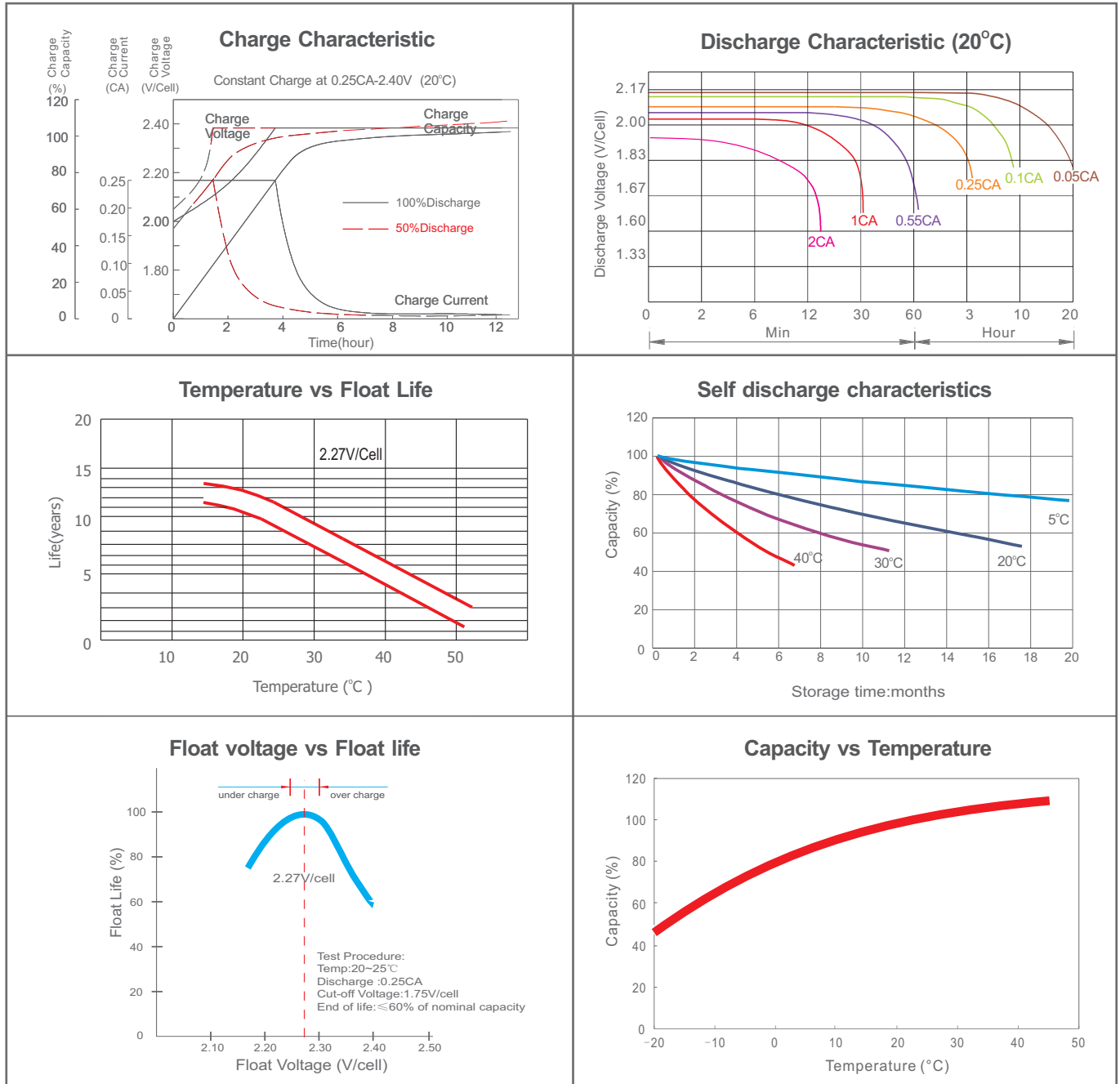

## FINAL VOLTAGE SETTINGS RECOMMENDED ACCORDING TO THE DISCHARGE CURRENT

Discharge Current I (A)	$I \leq 0.08C$	$0.08C \leq I < 0.2C$	$0.2C \leq I < 0.6C$	$0.6C \leq I < 1.0C$	$I \geq 1.0C$
Final of Voltage	$\geq 1.85V_{pc}$	$\geq 1.80V_{pc}$	$\geq 1.75V_{pc}$	$\geq 1.70V_{pc}$	$\geq 1.60V_{pc}$

## HEADQUARTERS AND SUBSIDIARIES

BSB Power Company Limited (HQ)  
 BSB Power Europe (France)  
 BSB Power Malaysia Sdn. Bhd  
 PT. BSB Indonesia  
 BSB Power (Thailand) Co., Ltd  
 BSB Power Company Pakistan Ltd

