

## DURATION SERIES VRLA BATTERY

By combining a newly developed corrosion resistance alloy and advanced curing process, BSB created a range of long life batteries - Duration range. The range features top termination and offers 12 years design life. This battery series is highly suited to UPS systems, switchgear, CATV and telecommunication systems applications.



### TECHNICAL SPECIFICATIONS

Nominal Voltage (V)	6 (3 cells per unit)
Designed Floating Life (20°C)	12 Years
Nominal Capacity (20°C)	180 Ah @ 10HR-rate (to 1.80Vpc)
Dimension (mm)	L307mm x W169mm x H225mm
Approx. Weight	27.0 kg (59.5 lbs)
Terminal Type	Female Copper Insert M8 (torque:10~12N.m)
Internal Resistance	Approx. 0.0032 Ohm (fully charged @ 20°C)
Max. Charge Current	37.5A
Max. Discharge Current (5S)	1000 A
Short Circuit Current	1850 A
Self Discharge	Approx. 3% per month @ 20°C
Ambient Temperature	Discharge: -20~60°C Charge: -20~60°C Storage: -20~45°C
Float Charge Voltage (20~25°C)	6.8-6.9V (-3mV/ cell / °C)
Equalize and cycle Use Charge Voltage (20~25°C)	7.2-7.4V (-5mV/ cell / °C)
Container Material	ABS (UL94-V0 optional)



ISO9001 ISO14001



#### Complied standards

- IEC 60896-21/22
- UL1989
- JIS C8704
- GB/T19639

### BATTERY DIMENSIONS

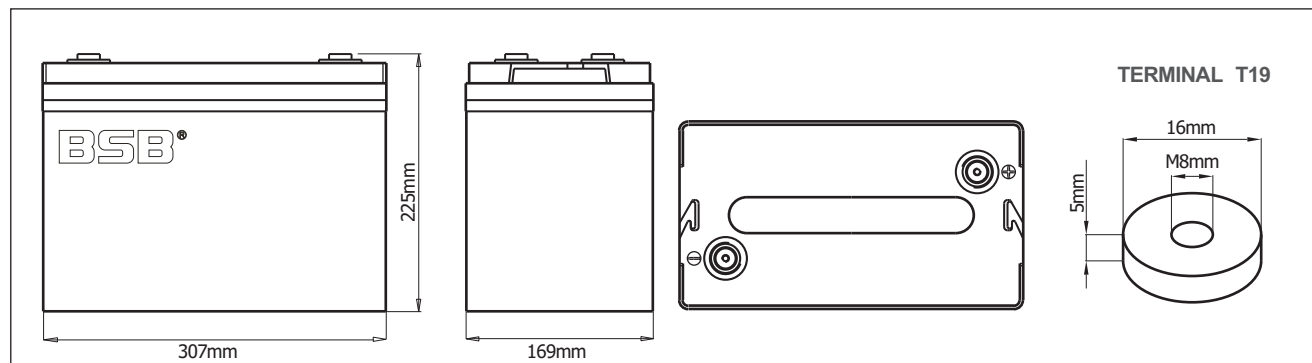

### BATTERY DISCHARGE TABLE

Constant Current Discharge Characteristics: Amps (25°C)												
F.V/Time	5 m in	10 m in	15 m in	30 m in	1 h	2 h	3 h	4 h	5 h	8 h	10 h	20 h
1.60V	540	398	329	203	122	70.7	51.0	40.7	33.9	23.1	19.1	10.3
1.67V	482	367	310	194	118	69.4	50.4	40.1	33.4	22.8	18.8	10.0
1.70V	430	334	293	186	116	68.5	49.8	39.7	33.1	22.5	18.6	9.82
1.75V	374	310	272	180	113	67.3	49.0	39.3	32.7	22.2	18.4	9.63
1.80V	331	282	254	172	110	65.9	48.1	38.4	31.9	21.7	18.0	9.45
1.85V	283	254	231	162	105	63.3	46.5	37.3	31.2	21.2	17.5	9.23

Constant Power Discharge Characteristics: W/cell (25°C)												
F.V/Time	5 m in	10 m in	15 m in	30 m in	1 h	2 h	3 h	4 h	5 h	8 h	10 h	20 h
1.60V	951	716	600	375	227	133	96.3	77.1	64.5	44.5	36.9	19.9
1.67V	859	667	570	360	222	131	95.8	76.5	64.1	44.1	36.6	19.6
1.70V	776	612	543	349	219	130	95.3	76.3	64.0	43.9	36.4	19.3
1.75V	684	575	510	340	216	129	94.6	76.1	63.7	43.7	36.2	19.1
1.80V	612	529	480	328	211	128	93.6	75.0	62.7	43.0	35.8	18.9
1.85V	533	482	442	313	203	124	91.3	73.5	61.7	42.3	35.0	18.5

## CHARACTERISTICS

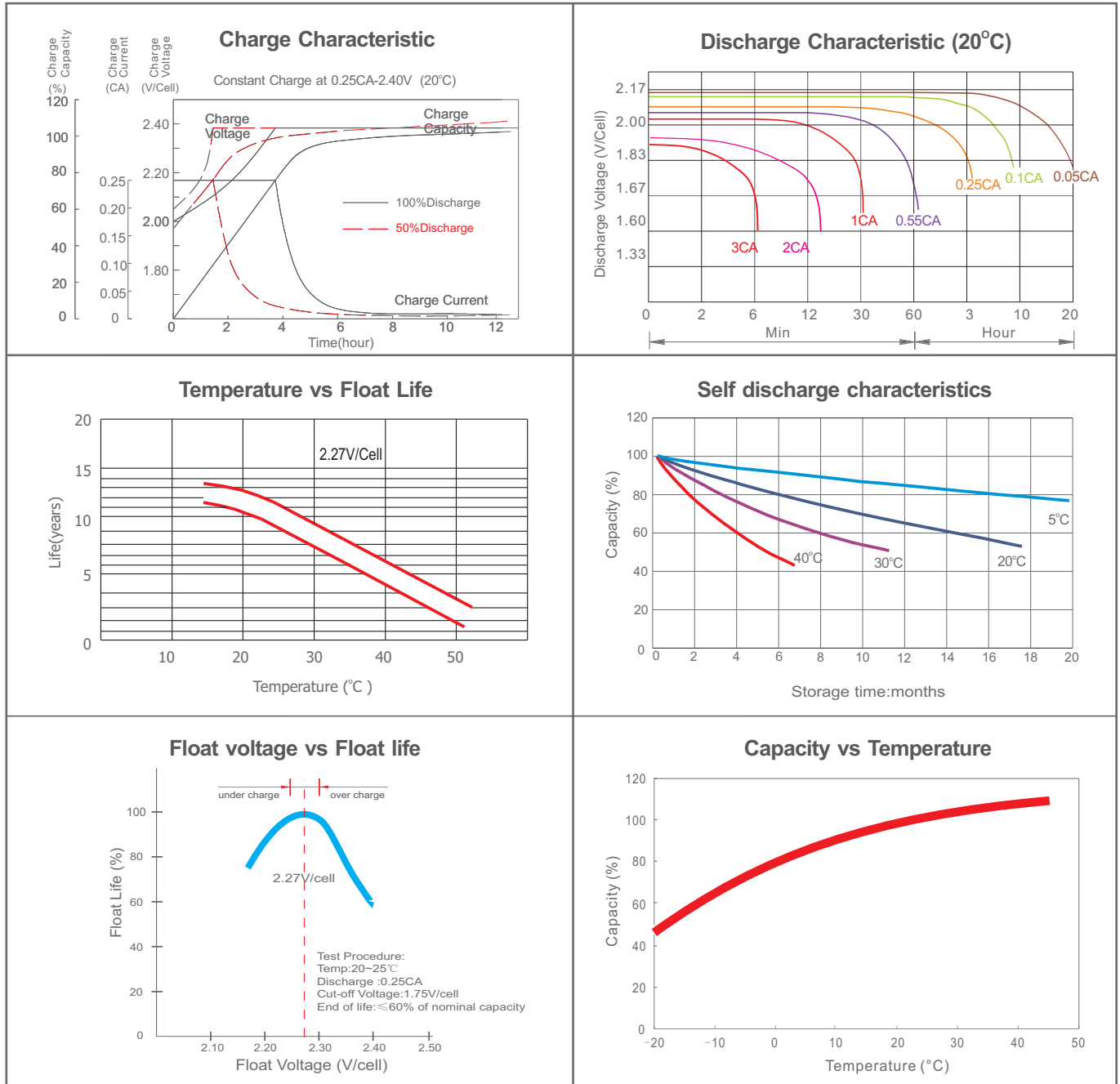

## FINAL VOLTAGE SETTINGS RECOMMENDED ACCORDING TO THE DISCHARGE CURRENT

Discharge Current I (A)	$I \leq 0.08C$	$0.08C \leq I < 0.2C$	$0.2C \leq I < 0.6C$	$0.6C \leq I < 1.0C$	$I \geq 1.0C$
Final of Voltage	$\geq 1.85V_{pc}$	$\geq 1.80V_{pc}$	$\geq 1.75V_{pc}$	$\geq 1.70V_{pc}$	$\geq 1.60V_{pc}$

## HEADQUARTERS AND SUBSIDIARIES

BSB Power Company Limited (HQ)  
 BSB Power Europe (France)  
 BSB Power Malaysia Sdn. Bhd  
 PT. BSB Indonesia  
 BSB Power (Thailand) Co., Ltd  
 BSB Power Company Pakistan Ltd

