

DURATION SERIES VRLA BATTERY

By combining a newly developed corrosion resistance alloy and advanced curing process, BSB created a range of long life batteries - Duration range. The range features top termination and offers 12 years design life. This battery series is highly suited to UPS systems, switchgear, CATV and telecommunication systems applications.



TECHNICAL SPECIFICATIONS

Nominal Voltage (V)	12 (6 cells per unit)
Designed Floating Life (20°C)	12 Years
Nominal Capacity (20°C)	230 Ah @ 10HR-rate (to 1.80Vpc)
Dimension (mm)	L522mm x W238mm x H223mm
Approx. Weight	66.0 kg (145.5 lbs)
Terminal Type	Female Copper Insert M8 (torque:10~12N.m)
Internal Resistance	Approx. 0.0028 Ohm (fully charged @ 20°C)
Max. Charge Current	57.5 A
Max. Discharge Current (5S)	1000 A
Short Circuit Current	4300 A
Self Discharge	Approx. 3% per month @ 20°C
Ambient Temperature	Discharge: -20~60°C Charge: -20~60°C Storage: -20~45°C
Float Charge Voltage (20~25°C)	13.6-13.8V (-3mV/ cell/ °C)
Equalize and cycle Use Charge Voltage (20~25°C)	14.4-14.8V (-5mV/ cell / °C)
Container Material	ABS (UL94-V0 optional)



ISO9001

ISO14001



Complied standards

- IEC 60896-21/22
- UL1989
- JIS C8704
- GB/T19639

BATTERY DIMENSIONS

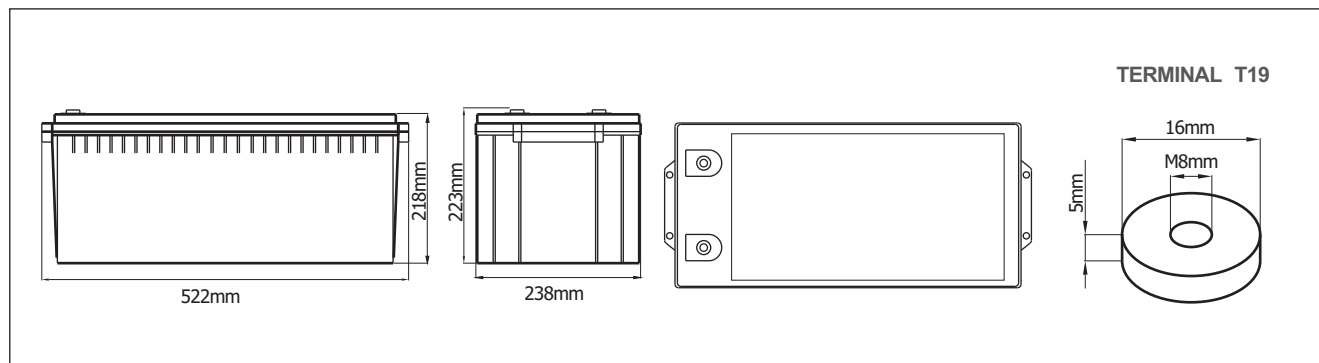

BATTERY DISCHARGE TABLE

Constant Current Discharge Characteristics: Amps (25°C)												
F.V/Time	5 m in	10 m in	15 m in	30 m in	1 h	2 h	3 h	4 h	5 h	8 h	10 h	20 h
1.60V	603	459	392	254	154	90.3	65.2	52.0	43.3	29.6	24.4	13.1
1.67V	538	423	369	243	150	88.7	64.4	51.3	42.7	29.2	24.1	12.8
1.70V	480	385	349	234	146	87.5	63.6	50.8	42.4	28.8	23.8	12.5
1.75V	417	357	324	225	143	86.0	62.6	50.2	41.8	28.4	23.5	12.3
1.80V	369	325	302	215	139	84.2	61.4	49.0	40.8	27.7	23.0	12.1
1.85V	316	293	275	203	133	80.9	59.4	47.6	39.8	27.1	22.4	11.8

Constant Power Discharge Characteristics: W/cell (25°C)												
F.V/Time	5 m in	10 m in	15 m in	30 m in	1 h	2 h	3 h	4 h	5 h	8 h	10 h	20 h
1.60V	1062	826	714	469	287	170	124	98.5	82.4	56.8	47.1	25.5
1.67V	960	769	678	451	281	168	123	97.8	82.0	56.4	46.8	25.1
1.70V	867	706	646	437	276	167	122	97.5	81.7	56.1	46.5	24.7
1.75V	763	663	607	426	273	165	121	97.3	81.4	55.8	46.2	24.4
1.80V	684	610	571	411	266	163	120	95.8	80.1	54.9	45.7	24.1
1.85V	595	556	526	391	257	158	117	93.9	78.8	54.1	44.8	23.7

CHARACTERISTICS

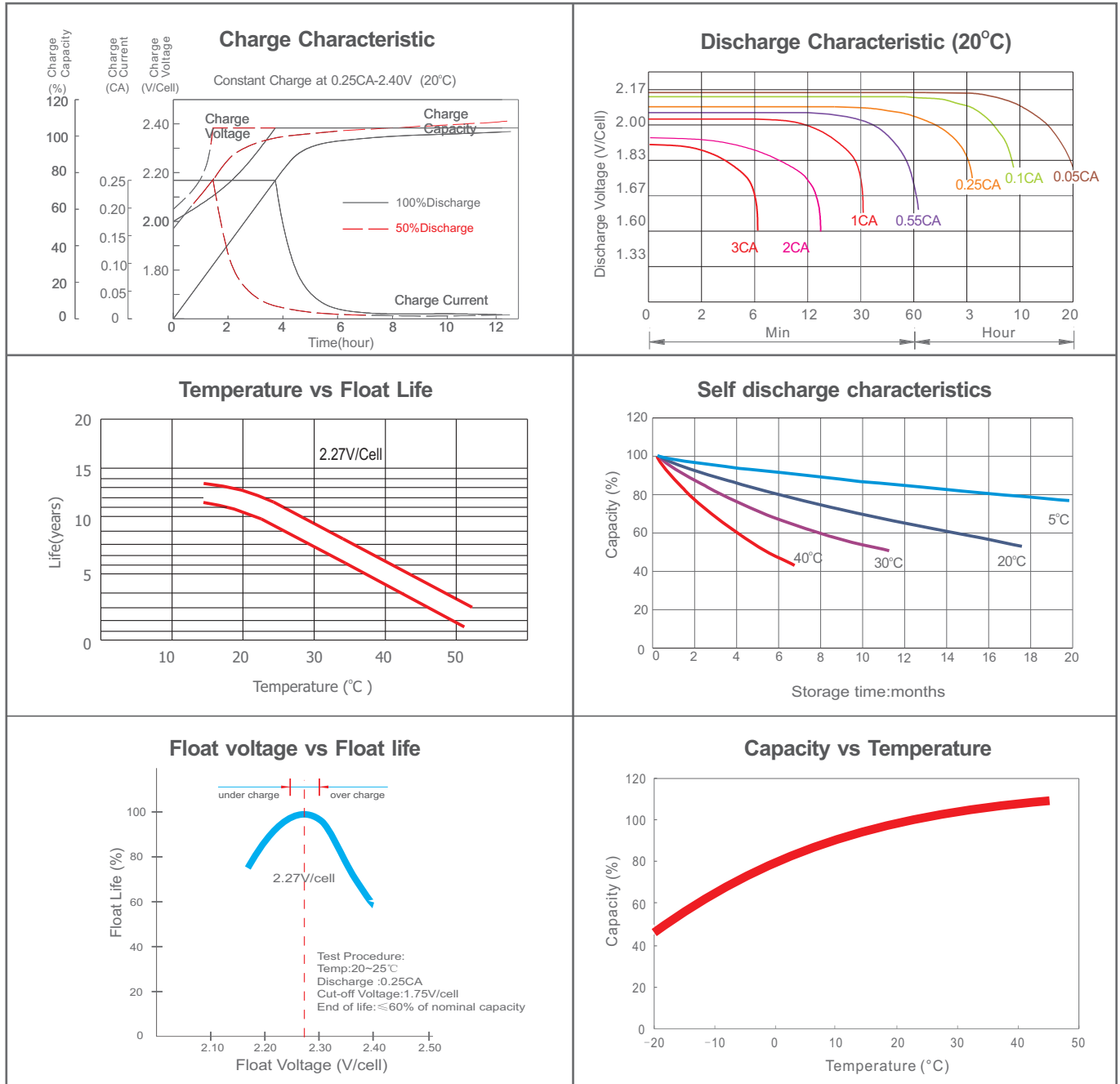

FINAL VOLTAGE SETTINGS RECOMMENDED ACCORDING TO THE DISCHARGE CURRENT

Discharge Current I (A)	$I \leq 0.08C$	$0.08C \leq I < 0.2C$	$0.2C \leq I < 0.6C$	$0.6C \leq I < 1.0C$	$I \geq 1.0C$
Final of Voltage	$\geq 1.85V_{pc}$	$\geq 1.80V_{pc}$	$\geq 1.75V_{pc}$	$\geq 1.70V_{pc}$	$\geq 1.60V_{pc}$

HEADQUARTERS AND SUBSIDIARIES

BSB Power Company Limited (HQ)
 BSB Power Europe (France)
 BSB Power Malaysia Sdn. Bhd
 PT. BSB Indonesia
 BSB Power (Thailand) Co., Ltd
 BSB Power Company Pakistan Ltd

