

DURATION SERIES VRLA BATTERY

By combining a newly developed corrosion resistance alloy and advanced curing process, BSB created a range of long life batteries - Duration range. The range features top termination and offers 12 years design life. This battery series is highly suited to UPS systems, switchgear, CATV and telecommunication systems applications.



TECHNICAL SPECIFICATIONS

Nominal Voltage (V)	12 (6 cells per unit)
Designed Floating Life (20°C)	12 Years
Nominal Capacity (20°C)	135 Ah @ 10HR-rate (to 1.80Vpc)
Dimension (mm)	L341mm x W173mm x H288mm
Approx. Weight	35.5 kg (78.3 lbs)
Terminal Type	Female Copper Insert M8 (torque:10~12N.m)
Internal Resistance	Approx. 0.0038 Ohm (fully charged @ 20°C)
Max. Charge Current	33.75A
Max. Discharge Current (5S)	1000 A
Short Circuit Current	3150 A
Self Discharge	Approx. 3% per month @ 20°C
Ambient Temperature	Discharge: -20~60°C Charge: -20~60°C Storage: -20~45°C
Float Charge Voltage (20~25°C)	13.6-13.8V (-3mV/ cell/ °C)
Equalize and cycle Use Charge Voltage (20~25°C)	14.4-14.8V (-5mV/ cell / °C)
Container Material	ABS (UL94-V0 optional)



ISO9001

ISO14001



Complied standards

- IEC 60896-21/22
- UL1989
- JIS C8704
- GB/T19639

BATTERY DIMENSIONS

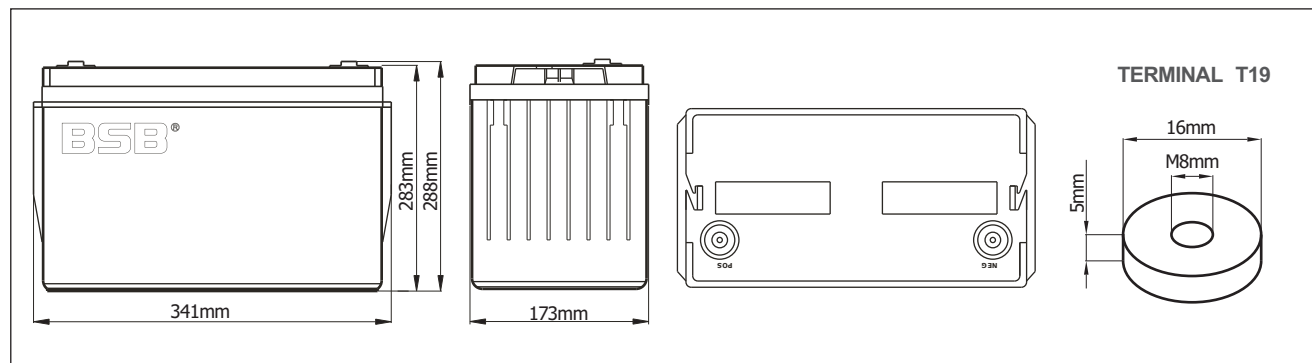

BATTERY DISCHARGE TABLE

Constant Current Discharge Characteristics: Amps (25°C)												
F.V/Time	5 m in	10 m in	15 m in	30 m in	1 h	2 h	3 h	4 h	5 h	8 h	10 h	20 h
1.60V	405	299	247	152	91.2	53.0	38.3	30.5	25.4	17.3	14.3	7.71
1.67V	361	275	232	145	88.9	52.1	37.8	30.1	25.1	17.1	14.1	7.53
1.70V	323	250	220	140	86.8	51.4	37.4	29.8	24.9	16.9	14.0	7.36
1.75V	280	232	204	135	85.0	50.5	36.8	29.5	24.5	16.7	13.8	7.22
1.80V	248	211	190	129	82.2	49.4	36.1	28.8	23.9	16.3	13.5	7.08
1.85V	212	190	173	122	78.7	47.5	34.9	27.9	23.4	15.9	13.1	6.92

Constant Power Discharge Characteristics: W/cell (25°C)												
F.V/Time	5 m in	10 m in	15 m in	30 m in	1 h	2 h	3 h	4 h	5 h	8 h	10 h	20 h
1.60V	713	537	450	281	170	99.5	72.2	57.8	48.4	33.3	27.6	15.0
1.67V	645	500	427	270	167	98.4	71.8	57.4	48.1	33.1	27.5	14.7
1.70V	582	459	407	262	164	97.9	71.5	57.3	48.0	32.9	27.3	14.5
1.75V	513	432	382	255	162	97.0	71.0	57.1	47.8	32.7	27.1	14.3
1.80V	459	397	360	246	158	95.7	70.2	56.3	47.0	32.2	26.8	14.2
1.85V	400	362	331	234	153	92.9	68.5	55.1	46.3	31.7	26.3	13.9

CHARACTERISTICS

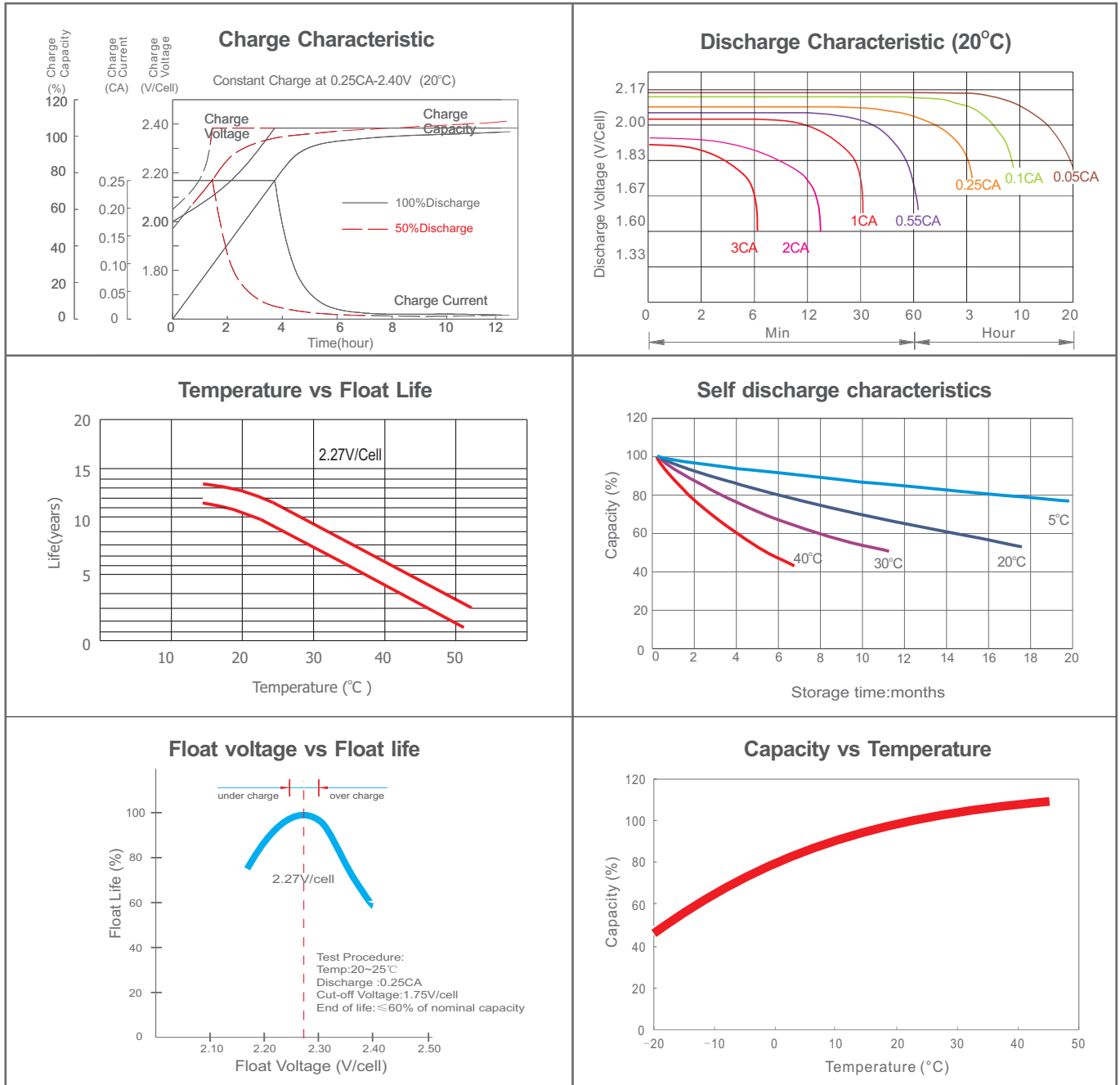

FINAL VOLTAGE SETTINGS RECOMMENDED ACCORDING TO THE DISCHARGE CURRENT

Discharge Current I (A)	$I \leq 0.08C$	$0.08C \leq I < 0.2C$	$0.2C \leq I < 0.6C$	$0.6C \leq I < 1.0C$	$I \geq 1.0C$
Final of Voltage	$\geq 1.85V_{pc}$	$\geq 1.80V_{pc}$	$\geq 1.75V_{pc}$	$\geq 1.70V_{pc}$	$\geq 1.60V_{pc}$

HEADQUARTERS AND SUBSIDIARIES

BSB Power Company Limited (HQ)
 BSB Power Europe (France)
 BSB Power Malaysia Sdn. Bhd
 PT. BSB Indonesia
 BSB Power (Thailand) Co., Ltd
 BSB Power Company Pakistan Ltd

